

Drive^{IT} Permanent Magnet Motors



Industrial^{IT}
—enabled™

ABB

Making you more competitive

ABB has been manufacturing motors for over 100 years, providing products designed to be reliable, efficient and cost effective. The new permanent magnet motor series extends the effective nominal speed range of the rugged industrial work-horses, the AC motor, down to 100 - 850 r/min. These motors simplify drive systems by effectively eliminating the need for speed reduction devices.



Industrial^{IT}

As a key element of its business strategy, ABB has committed to a broad program of product development and positioning under the Industrial^{IT} umbrella. This initiative is geared towards increasing standardization of ABB products as the 'building blocks' of larger solutions, while incorporating functionality that will allow multiple products to interact seamlessly as components of real-time automation and information systems.

Motors and generators represent one of the fundamental building blocks in the Industrial^{IT} architecture.

ABB (www.abb.com) is a leader in power and automation technologies that enable utility and industry customers to improve performance while lowering environmental impacts. The ABB Group of companies operates in around 100 countries and employs around 113,000 people.

Drive^{IT} Permanent Magnet Motors

Sizes 280 to 560

Contents	Page
Permanent magnet motors for variable speed applications.....	4
Application characteristics	5
Motor characteristics	6
ABB's industrial drive for permanent magnet motors	9
Mechanical design.....	10
Stator frame	
Drain holes	
Terminal box	
Bearings	
Bearing seals	
Bearing life	
Lubrication	
Pulley diameter	
Permissible loadings on the shaft end	
Rating plates	17
Ordering information.....	18
Data tables	19
Variant codes	44
Dimension drawings	51
Permanent magnet motors in brief	67
ABB Motors' total product offer	70
Visit to our web site.....	71

Permanent magnet motors for variable speed applications

Drive^{IT} low voltage permanent magnet motors are synchronous motors, designed to drive low speed applications directly, without a gearbox. Ideal applications are paper machines, low speed pumps, extruders etc. The motors are designed exclusively for frequency converter supply. ABB's frequency converters from the ACS 600, ACS 800 and ACS 6000 series are available with permanent magnet motor software.

ABB's permanent magnet motors are based on the well-known and reliable M3BP and HXR motor design. The greatest difference is the modern rotor construction, where the squirrel cage or magnetisation windings have been replaced by highly efficient permanent magnets. This means that the major benefits of squirrel cage and synchronous motors are combined to one product, called M3BJ, M3LJ or AMZ.

The ABB Direct Drive system offers several valuable benefits:

- Higher overall efficiency of a drive system
- Excellent controllability and adjustability, even without a pulse encoder. For instance, no pulse encoder is needed with paper machine drives
- Fewer components means: less maintenance and less down-time
- Easier and faster installation
- Space savings

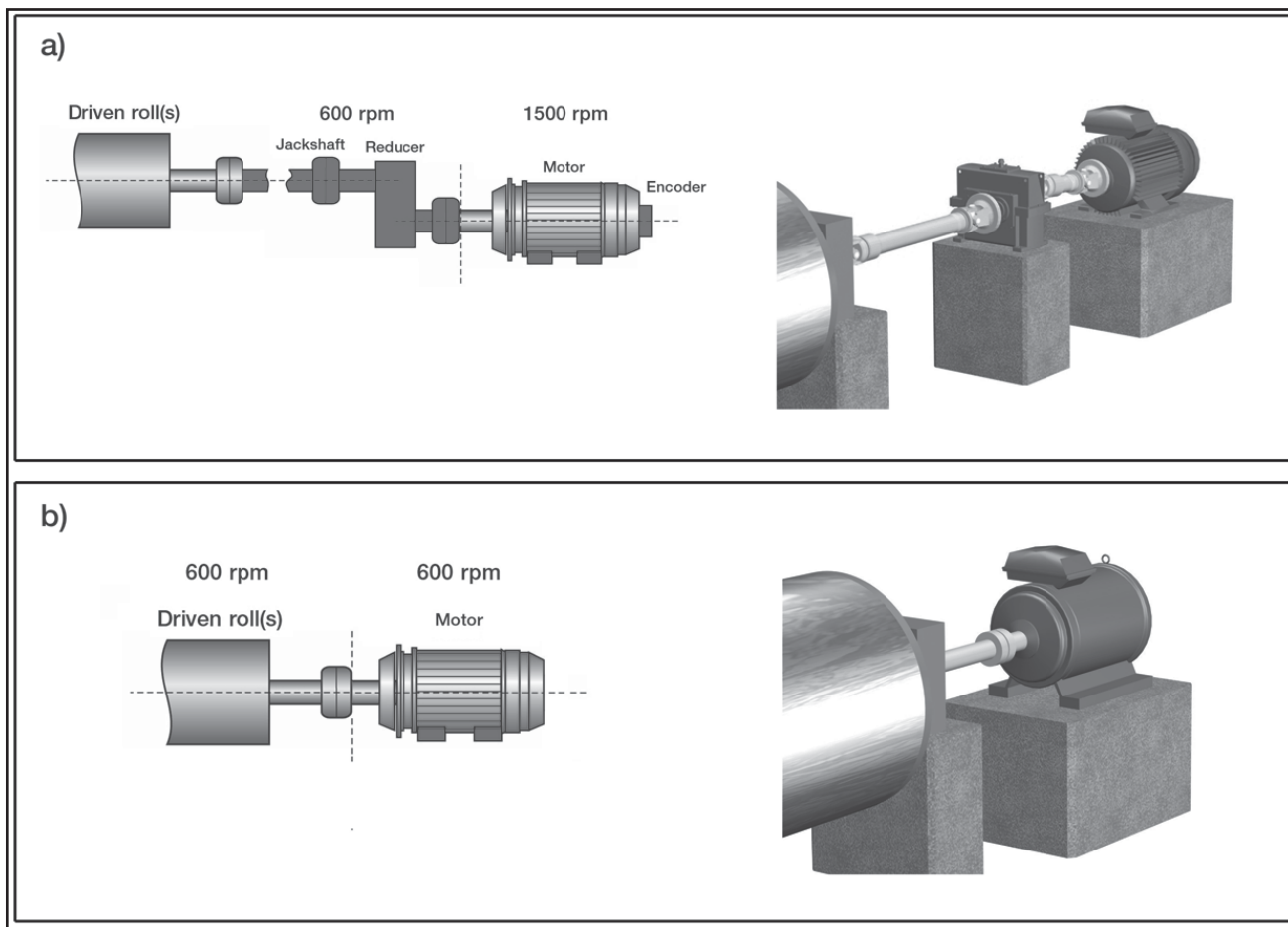

Conventional drive system (a) compared to Direct Drive (b).

Application characteristics

Technically, the permanent magnet motor could be used in any application up to about 850 r/min. However, not all applications may be economic.

Permanent magnet motor solution can typically replace:

- A traditional AC motor and gearbox with frequency converter.
- A traditional low speed AC motor, typically 10 to 16-pole or slower with frequency converter.
- A DC motor with DC drive and gearbox.

The permanent magnet motor is ideal in the following cases:

- Where the application is speed controlled, for instance with a frequency converter.
- Where the nominal load speed, for example the gearbox output speed, is 100 to 850 r/min or ideally 300 to 600 r/min.
- Where the nominal load torque is between 1000 and 50 000 Nm *).
- Where the required short-time overloadability is limited to 120 - 150 %.
- The greatest savings are achieved if the current speed reduction system is expensive or otherwise problematic.

- Constant torque or quadratic torque applications are the most ideal. Constant power speed range should ideally be limited to 20 % over nominal speed.

$$*) T \text{ [Nm]} = \frac{P \text{ [kW]} \times 9550}{\text{load r/min}}$$

In the case of motor and gearbox solution:

- P is the power of the existing motor power
- 'load r/min' is the speed in r/min of the output shaft of the gear box

Example:

Motor 160 kW, max. motor speed 1500 r/min. Gearbox with $i = 5$
Gearbox output speed (= load speed) = $1500 / 5 = 300$ r/min

$$T = \frac{160 \times 9550}{300} = 5093 \text{ Nm}$$

See 'Motor characteristics section 4. Motor selection example'.

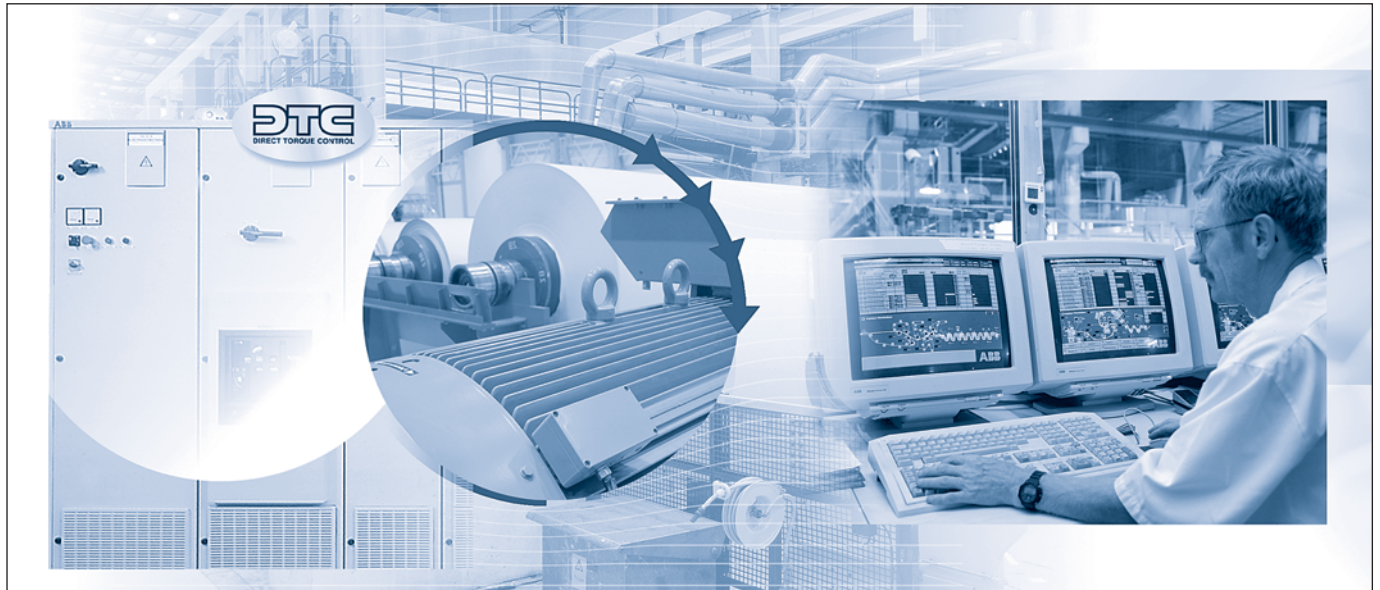

Motor characteristics

The rotor magnetization is achieved by the permanent magnets installed inside the rotor. This means the amount of magnetizing current drawn from the supply network is minimal. For this reason, the power factor of these motors is considerably higher compared to squirrel cage motors with the same nominal speeds. In practice, this means smaller frequency converters and supply units.

1. Loadability

Motors with separate cooling (IC 416) or liquid cooling can deliver full torque continuously at any speed between zero and nominal speed (n_n). The continuous output torque of self-cooled (IC 411) motors must be derated according to the applicable speed range. Note that the nominal torque of a self-cooled (IC 411) motor is not equal to the nominal torque of the same motor with separate cooling (IC 416). Derating factors can be found in Figure 1. Above nominal speed all motors can deliver constant power (CP) up to 1.2 times n_n .

This catalogue includes all available M3BJ and M3LJ type motors. A greater speed and output range is available in the AMZ series of motors. The types listed in this catalogue represent the torque range for each frame size.

2. Speed Range

Generally the speed range of these motors is from zero to 1.2 times the nominal speed. The voltage, which is induced by the permanent magnets to the stator windings, is proportional to the rotational speed. At speeds higher than 1.2 times n_n , the voltage may be too high for the insulation of the motor and the supply system, as well as for the frequency converter. In some cases the

maximum speed is limited to n_n . The maximum speed for the motors at different voltage levels is listed for each motor in the technical data section. If higher speed is needed, please contact ABB.

3. Overloadability

The permanent magnet motors have limited short-time overloadability, especially with the IC 416 and liquid cooled versions. The T_{max}/T_N values in the technical tables represent the available overloadability with frequency converter supply. Necessary margins are already included. There is no need to add any margins to this value. This value does not represent the pull-out torque value according to IEC standards.

4. Motor selection

Motor selection step-by-step:

1. Find the correct section based on network voltage.
2. Select between self cooled, IC 411 and forced ventilated, IC 416 (or liquid) cooled data tables. A motor with forced ventilation, IC 416 is usually the most economical solution.
3. Select the base speed. The most economical solution is achieved by selecting a motor with lowest base speed. Note however the maximum speed given for each motor type.
4. Generally, the motor can be selected based on torque when the base speed of the load is below the motors base speed. If motors base speed is below loads base speed, the motor selection is based on power. In any case make sure that the motor has enough torque throughout the speed range.

Figure 1. Permanent magnet synchronous motor loadability with ACS 600 and ACS 800 Frequency Converter.

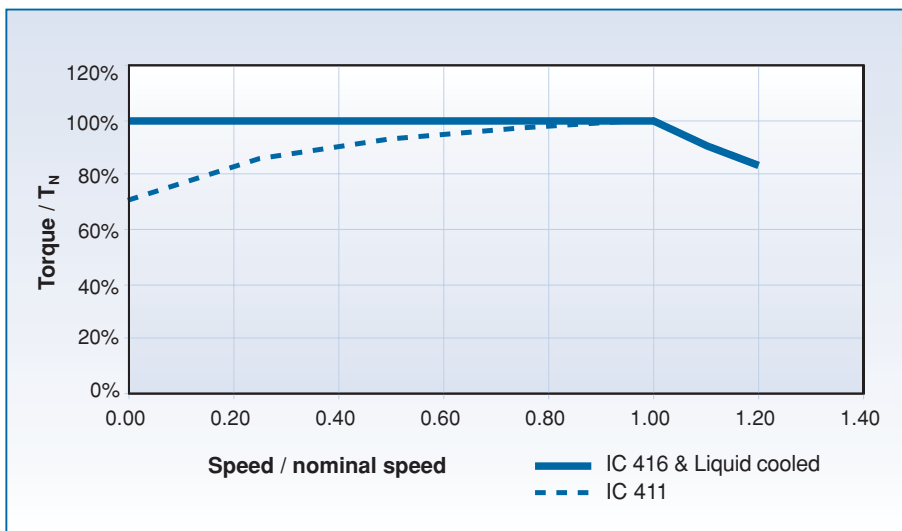

Example

Network voltage: 500 V

Load: Constant torque 8000 Nm, 100-400 r/min, 335 kW at 400 r/min

Cooling: IC 416 cooling

In the 500 V section there are 375 r/min and 433 r/min motor base speeds.

In the case of the 375 r/min motor base speed, the motor's base speed is below the base speed of the load and the motor selection is based on power as the motor is working on the "constant power" range. The M3BJ 400LC / 3GBJ406530-ADG183706 motor can deliver 366 kW between 375 r/min and 450 r/min and 9309 Nm between 0-375 r/min. It meets the application requirements.

In the case of 433 r/min base speed, the motor's base speed is above the load's base speed and the motor selection is based on torque as the motor is working on its constant torque range throughout the load's speed range. The M3BJ 400LC / 3GBJ406530-ADG183708 can deliver 8906 Nm between 0 - 433 r/min. Also this motor meets the application requirements.

However the 375 r/min motor needs less current as it has reached the field weakening point and full inverter output voltage. This minimizes the inverter size and optimizes the drive system economically.

The permanent magnet motors will be included in the DriveSize program during 2004. The software will include all M3BJ, M3LJ and AMZ type motors.

5. Insulation protection

The 280 to 400 size motors are equipped with reinforced insulation as standard, thus dU/dt-filter is needed only above 600 V.

The 500 to 560 size motor are made with form wound windings with Micadur® Compact Industry Insulation system (class F). It has a sufficient insulation level for a IGBT converter even without output chokes or dU/dt filters. For more information, please see the brochure 'Micadur® Compact Industry, Insulation System for Rotating Electrical Machines' (code 3BFP 001 980 R0101 REV B 06/2003).

6. Bearing currents

Bearing voltages and currents must be avoided in all motors. When using ABB IGBT frequency converters properly dimensioned filters at the converter output must be used according to the instructions in figure 2. (For other alternatives and converter types, please contact ABB)

When ordering, clearly state the alternative to be used. All motors listed in this catalogue have insulated bearings or bearing systems at the non-drive end as standard.

For more information about bearing currents and voltages, please consult ABB document 3GZF500930-8 or contact ABB.

Figure 2. Selection rules for insulation and filtering for permanent magnet motors

Motor nominal power on frame size			
	$P_N < 350 \text{ kW}$, IEC 280 to 355	$P_N \geq 350 \text{ kW}$ or IEC 400	IEC 500 and 560
$U_N \leq 500 \text{ V}$	Standard motor	Standard motor	Standard motor + Common mode filters
$U_N \leq 600 \text{ V}$	Standard motor	Standard motor + Common mode filters	
$U_N \leq 690 \text{ V}$	Standard motor +dU/dt –filter (reactor)	Standard motor + dU/dt –filter (reactor) + Common mode filters	

dU/dt filter

These filters are series reactors, which decrease the rate of change of the phase and main voltages and thus reduce voltages and reduce voltage stress in the windings. dU/dt filters also decrease common mode currents and the risk of bearing currents. They are designed to limit the dU/dt rate of the main voltage at motor terminals to approx. 1 kV/μs.

Common mode filters

Common mode filters consist of toroidal cores installed around motor cables or onto the busbars inside frequency converter. These filters reduce common mode currents in VSD applications and thus decrease the risk of bearing currents. Common mode filters do not significantly affect the phase or main voltages on motor terminals. For more information and product codes, please contact ABB.

7. Cabling, grounding and EMC

The use of a frequency converter causes some further requirements to the cabling and grounding of the drive system. The motor must be cabled by using shielded symmetrical cables and cable glands providing 360° bonding (also called EMC-glands).

For motors frame size IEC 280 and upward, additional potential equalization between the motor frame and the machinery is needed, unless they are installed on a common steel fundament. When a steel fundament is used equalize potential, the high frequency conductivity of this connection should be checked. To fulfill the EMC requirements, special EMC cable(s) must be used in addition to the correct cable gland mounting, with special, additional grounding pieces.

More information about grounding and cabling of a variable speed drive can be found from the manual 'Grounding and cabling of the drive system' (Code: 3AFY 61201998 R0125 REV A).

8. Reverse power

Magnetic flux is present in the motor at all times due to the permanent magnets in the rotor. The motor generates voltage if rotated. Motor rotation must be prevented before opening the terminal box. If there is a possibility that the motor may be rotated when the supply system is cut off, it is recommended that there is a proper switch disconnecting the motor from the supply system to ensure safe working.

ABB's industrial drive for permanent magnet motors

Drive^T Low Voltage AC Drives are used to control the speed and torque of a standard induction motor. Now with ACS 800 series single drives and multidrives it is possible to control the ABB permanent magnet synchronous motors (PMSM) as well.

ACS 800 PMSM control application program provides the same excellent Direct Torque Control (DTC) performance and control accuracy developed by ABB making speed encoders and/or rotor position measurement unnecessary.

One of the main benefits of the ACS 800 series is a wide range of drive products with common technologies. This includes e.g. compact design, DTC, common user and process interfaces, flexible and programmable I/Os, software tools for sizing, commissioning and maintenance as well as common spare parts.

Main benefits of the ACS 800 PMSM control are the ability to start a permanent magnet motor encoderless with estimated rotor position and to produce full torque within 200 ms after the start command. Also very accurate torque linearity can be achieved down to 2 % of the nominal speed of the PM motor.

Safety, feasibility and dimensioning considerations:

- Rotating PM motor generates Back-EMF voltage, thus a separate protective device must be used, e.g. a safety switch by the motor.
- Field weakening is very limited. In case of an active load, the intermediate circuit must be protected against over speed/over voltage.
- AC drive needs to be over dimensioned by 10 % of the nominal motor current.

To select the correct drive please refer to the corresponding ABB industrial drive catalogue and use the DriveSize dimensioning tool.

- ACS 800 Catalogue for single drive
- ACS 800 Technical catalogue for multidrive

For more information of the PMSM control application program.

- Supplement to Firmware Manual – Permanent Magnet Synchronous Machine Drive Application Program
- ACS800 Firmware Manual for System Application Program



Mechanical design

Stator frame

Air cooled motors are constructed with cast iron frame, feet and bearing housing.

Liquid cooled motors are constructed with welded steel frame and feet, and cast iron bearing housing.

Drain holes

All motors are fitted with drain holes and closable plugs. The plugs are open on delivery. When mounting the motor, ensure that the drain holes face downwards.

In case of vertical mounting, the 280 to 400 size motors' upper plug should be hammered home completely. The lowest plug(s) on the end shields should be open. In very dusty environments, all plugs could be hammered home.

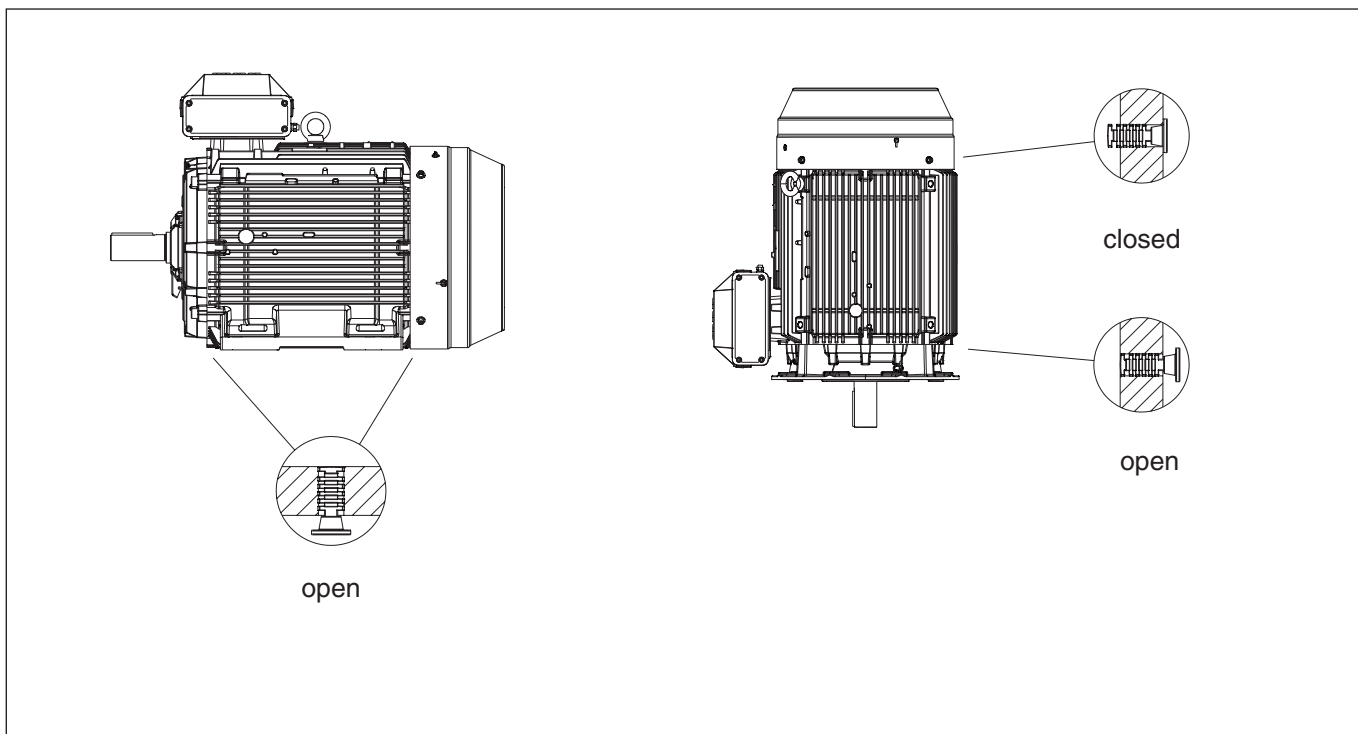

Terminal box for frame sizes 280 to 400

The terminal box can be turned 4 x 90°, to allow cable entry from either side of the motor.

Degree of protection of standard terminal box is IP 55.

The terminal box is equipped with cable glands or cable boxes as standard.

To enable the supply of suitable terminations for the motor, please state cable type, quantity and size when ordering. Non-standard design of terminal boxes, e.g. size, degree of protection, are available as options.

Co-ordination of terminal boxes and cable entries for frame sizes 280 to 400

The terminal box is equipped with cable glands or cable boxes as standard according to the table below. Other types are available on request.

Note correct variant code according to motor nominal speed.

EMC-cable connection is recommended; this is available as variant code 704. Please consult ABB's manual 'Grounding and cabling of the drive systems' (Code: 3AFY 61201998).

Motor size	Variant code	Terminal box	Max amps D/Y	Terminal box opening	Flange or adapter	Cable box or cable gland	Gland thread	Cable diameter mm	Max. conn. cable area
280SMB	705	210	260/150	C	3GZF294730-748	2x 3GZF294730-612	2xM50x1.5	2x 26-35	2x150
315SMC	705	370	470/270	D	3GZF294730-753	2x 3GZF294730-613	2xM63x1.5	2x 32-49	2x240
315MLA	705	370	470/270	D	3GZF294730-753	2x 3GZF294730-613	2xM63x1.5	2x 32-49	2x240
315LKB	705	370	470/270	D	3GZF294730-753	2x 3GZF294730-613	2xM63x1.5	2x 32-49	2x240
315LKC	705	370	470/270	D	3GZF294730-753	2x 3GZF294730-613	2xM63x1.5	2x 32-49	2x240
355SMB	705	370	640/370	D	3GZF294730-753	2x 3GZF294730-613	2xM63x1.5	2x 32-49	2x240
355MLB	705	370	640/370	D	3GZF294730-753	2x 3GZF294730-613	2xM63x1.5	2x 32-49	2x240
355LKB	705	370	640/370	D	3GZF294730-753	2x 3GZF294730-613	2xM63x1.5	2x 32-49	2x240
400LC	705	370	640/370	D	3GZF294730-753	2x 3GZF294730-613	2xM63x1.5	2x 32-49	2x240
280SMB	706	210	260/150	C	3GZF294730-749	2x 3GZF294730-613	2xM63x1.5	2x 32-49	2x150
315SMC	706	370	470/270	D	3GZF294730-753	2x 3GZF294730-613	2xM63x1.5	2x 32-49	2x240
315MLA	706	370	470/270	D	3GZF294730-753	2x 3GZF294730-613	2xM63x1.5	2x 32-49	2x240
315LKB	706	370	470/270	D	3GZF294730-753	2x 3GZF294730-613	2xM63x1.5	2x 32-49	2x240
315LKC	706	370	470/270	D	3GZF294730-753	2x 3GZF294730-613	2xM63x1.5	2x 32-49	2x240
355SMB	706	370	640/370	D	3GZF294730-753	2x 3GZF294730-613	2xM63x1.5	2x 32-49	2x240
355MLB	706	370	640/370	D	3GZF294730-753	2x 3GZF294730-613	2xM63x1.5	2x 32-49	2x240
355LKB	706	370	640/370	D	3GZF294730-753	2x 3GZF294730-613	2xM63x1.5	2x 32-49	2x240
400LC	706	370	640/370	D	3GZF294730-753	2x 3GZF294730-613	2xM63x1.5	2x 32-49	2x240
280SMB	707	210	260/150	C	3GZF294730-749	2x 3GZF294730-613	2xM63x1.5	2x 32-49	2x150
315SMC	707	370	470/270	D	3GZF294730-753	2x 3GZF294730-613	2xM63x1.5	2x 32-49	2x240
315MLA	707	370	470/270	D	3GZF294730-753	2x 3GZF294730-613	2xM63x1.5	2x 32-49	2x240
315LKB	707	370	470/270	D	3GZF294730-753	2x 3GZF294730-613	2xM63x1.5	2x 32-49	2x240
315LKC	707	370	470/270	D	3GZF294730-753	2x 3GZF294730-613	2xM63x1.5	2x 32-49	2x240
355SMB	707	370	640/370	D	3GZF294730-753	2x 3GZF294730-613	2xM63x1.5	2x 32-49	2x240
355MLB	707	370	640/370	D	3GZF294730-753	2x 3GZF294730-613	2xM63x1.5	2x 32-49	2x240
355LKB	707	370	640/370	D	3GZF294730-753	2x 3GZF294730-613	2xM63x1.5	2x 32-49	2x240
400LC	707	750	950/550	E	3GZF294730-944	3GZF294730-301		2x 48-60	4x240
280SMB	708	210	260/150	C	3GZF294730-749	2x 3GZF294730-613	2xM63x1.5	2x 32-49	2x150
315SMC	708	370	470/270	D	3GZF294730-753	2x 3GZF294730-613	2xM63x1.5	2x 32-49	2x240
315MLA	708	370	470/270	D	3GZF294730-753	2x 3GZF294730-613	2xM63x1.5	2x 32-49	2x240
315LKB	708	370	470/270	D	3GZF294730-753	2x 3GZF294730-613	2xM63x1.5	2x 32-49	2x240
315LKC	708	370	470/270	D	3GZF294730-753	2x 3GZF294730-613	2xM63x1.5	2x 32-49	2x240
355SMB	708	370	640/370	D	3GZF294730-753	2x 3GZF294730-613	2xM63x1.5	2x 32-49	2x240
355MLB	708	750	950/550	E	3GZF294730-944	3GZF294730-301		2x 48-60	4x240
355LKB	708	750	950/550	E	3GZF294730-944	3GZF294730-301		2x 48-60	4x240
400LC	708	750	950/550	E	3GZF294730-945	2x 3GZF294730-301		2x(2x 48-60)	4x240

Motor sizes 280 to 315

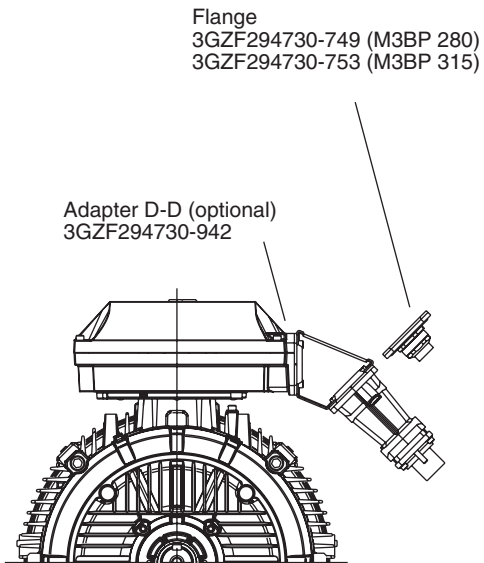

Motor sizes 355 and 400

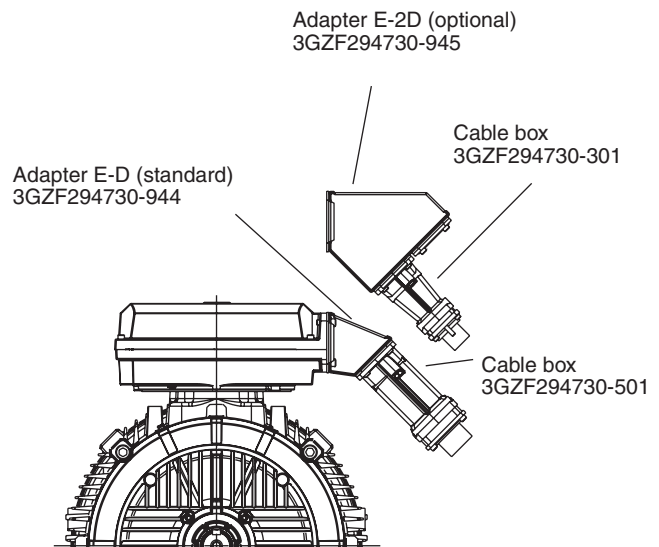

Auxiliary devices (view from N-end)

Cable glands for auxiliary devices
as standard 2 x M20 x 1.5.

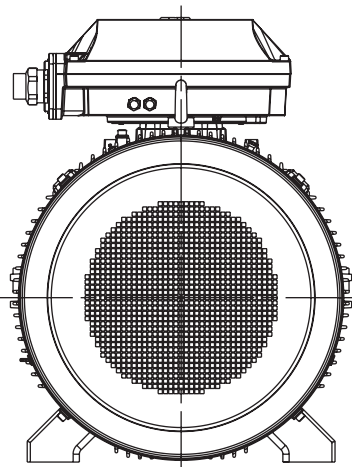

Motor sizes 280 to 400 Dimensions for terminal box inlets

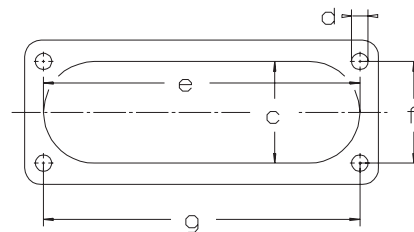

Inlet	c	e	f	g	d
C	62	193	62	193	M8
D	100	300	80	292	M10
E	115	370	100	360	M12

Terminal box for frame sizes 500 and 560

The terminal box can be turned 180°, to allow cable entry from either side of the motor.

To enable the supply of suitable terminations for the motor, please state cable type, quantity and size when ordering. Non-standard design of terminal boxes, e.g. size, degree of protection, are available as options.

Degree of protection of standard terminal box is IP 55.

The terminal box is equipped with Roxtec cable bushings as standard.

Main terminal box

Horizontal machine

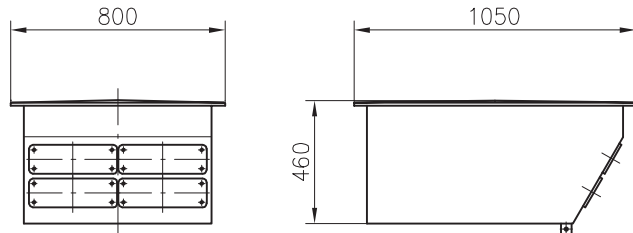

Vertical machine

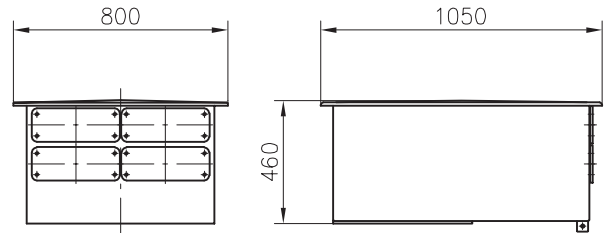

Cable bushings

FL33 opening

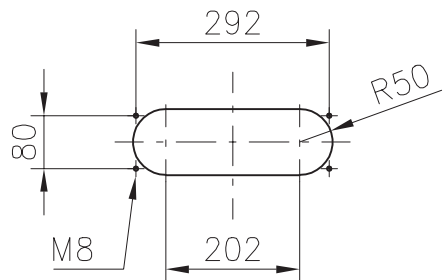

Roxtec

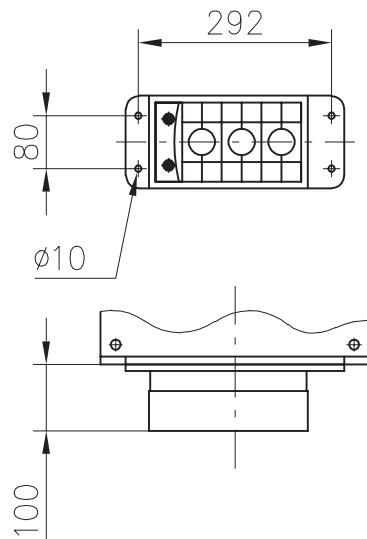

Undrilled plate

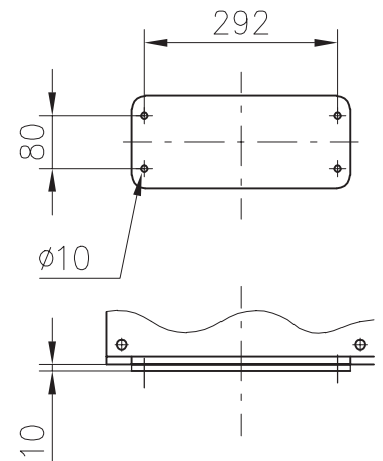

Roxtec cable bushing / FL33 opening

Type of the cable	Number of cables	Max. outer diameter of the cables (mm)
3-phase	1	70 - 98
	2	50 - 70
	3 - 6	32 - 50
1-phase	7 - 8	22 - 32
	3 - 6	32 - 50
	9 - 12	22 - 32

Frame sizes 500 to 560

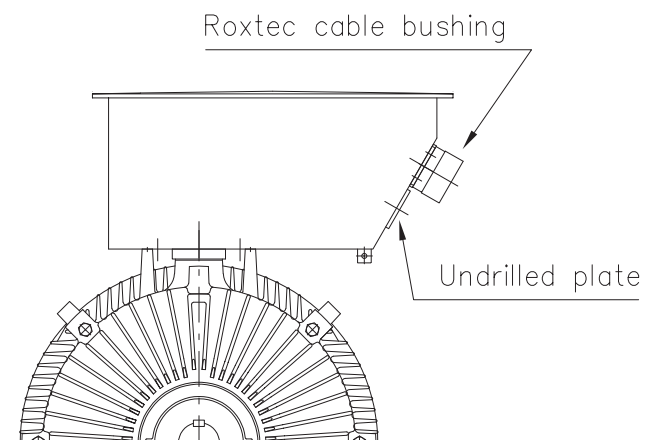

Bearings

The horizontally mounted motors are provided with single-row deep groove ball bearings as listed in the table.

Vertical mounting of motor sizes 280 to 400 must be reviewed with ABB case-by-case.

Motor sizes 500 and 560 can be mounted also in vertical position. Vertical mounting requires a single-row angular contact ball bearing at N-end as listed in the table.

Motor size	Mounting	Standard design Bearings	
		D-end	N-end
280 ¹⁾	Horizontal	6316/C3	6316M/C3 VL0241
315 ¹⁾	Horizontal	6319/C3	6316M/C3 VL0241
355 ¹⁾	Horizontal	6322/C3	6316M/C3 VL0241
400 ¹⁾	Horizontal	6324/C3	6319M/C3 VL0241
500	Horizontal	6330/C3	6330/C3
500	Vertical	6330/C3	7330 BM
560	Horizontal	6338/C3	6338/C3
560	Vertical	6338/C3	7338 BM

¹⁾ Vertical mounted motors on request

Bearing seals

The size and type of suitable seals are in accordance with the table below:

Motor size	Standard design D-end	N-end	Alternative design D-end	N-end
280	Axial seal VS80	Axial seal VS80	Labyrinth seal Radial seal 80x110x10	Labyrinth seal Radial seal 80x110x10
315	Axial seal VS95	Axial seal VS80	Labyrinth seal Radial seal 95x125x10	Labyrinth seal Radial seal 80x110x10
355	Labyrinth seal	Axial seal VS80	-	Labyrinth seal
400	Labyrinth seal	Axial seal VS95	-	Labyrinth seal
500 - 560	Labyrinth seal	Labyrinth seal	Inpro-seal	Inpro-seal

Motor sizes 280 to 400

Labyrinth seal

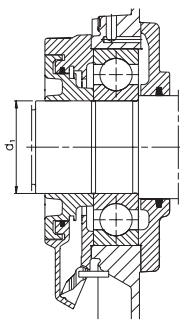

V-ring

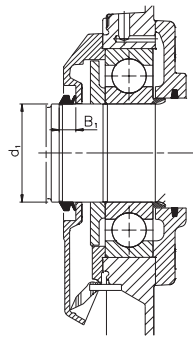

Radial seal

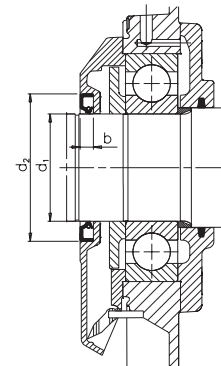

Motor sizes 500 and 560

D-end
Axially locked

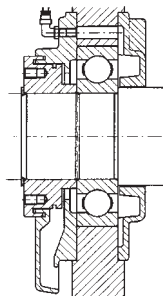

N-end
Axially free

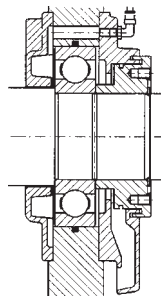

N-end in vertical machines
Angular contact ball bearing

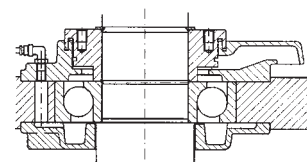

Bearing life

The nominal life L_{10h} of a bearing is defined according to ISO as the number of operating hours achieved or exceeded by 90% of identical bearings in a large test series under certain specified conditions. 50% of the tested bearings achieve at least five times the L_{10h} life. The values in the table are calculated without any external forces on motor bearings.

Motor size	Mounting	L_{10h} [hours]
280 to 400	Horizontal	≥ 80000
280 to 400	Vertical	On request
500	Horizontal	≥ 58000
500	Vertical	≥ 63000
560	Horizontal	≥ 42000
560	Vertical	≥ 50000

Lubrication

Permanent magnet motors have grease valve lubrication for lubrication in service. The lubrication intervals and grease quantity are stated in the maintenance instructions, which are delivered with the motor. If a motor is equipped with a lubrication instruction plate, the instructions on the plate should be followed.

On delivery the motors are lubricated with Esso Unirex S2 grease, which is the recommended grease type. The maintenance instructions include other compatible grease types.

Pulley diameter

When the desired bearing life has been determined, the minimum permissible pulley diameter can be calculated using F_R , as follows:

$$D = \frac{1.9 \cdot 10^7 \cdot K \cdot P}{n \cdot F_R}$$

where:

D = diameter of pulley, mm

P = power requirement, kW

n = motor speed, r/min

K = belt tension factor, dependent on belt type and type of duty. A common value for V-belts is 2.5.

F_R = permissible radial force

Permissible loadings on the shaft end

The table below gives the permissible radial force at shaft end ($F_{X_{max}}$) in Newton, assuming zero axial force. The values are based on 40,000 hours bearing life on normal conditions for motor sizes 280 to 400. For motor sizes 500 and 560 values are based on 30,000 hours bearing life.

Motors are foot-mounted IM B3 version with the force directed radially. In some cases, the strength of the shaft affects the permissible forces.

Permissible loads of simultaneous radial and axial forces will be supplied on request.

Motor size	Length of shaft extension	Ball bearings
	E (mm)	40,000 hours $F_{X_{max}}$ (N)
280 SM_	140	5000
315 SM_	170	5000
315 ML_	170	5000
315 LK_	170	5000
355 SM_	210	5000
355 ML_	210	5000
355 LK_	210	5000
400 L_	210	5000

Motor size	Length of shaft extension E (mm)	30,000 hours		
		300 r/min $F_{X_{max}}$ (N)	600 r/min $F_{X_{max}}$ (N)	850 r/min $F_{X_{max}}$ (N)
500	250	12000	6000	4000
560	300	13600	5600	3000

Rating plates

Motor sizes 280 to 400

ABB Oy, Electrical Machines
LV Motors, Vaasa, Finland

3 ~ Motor M3BJ 315LKC 12 B3

PERMANENT MAGNET SYNCHR. MOTOR

S1 SPEC.INSUL. No. 0312-010512426

Ins.cl. F IP 55

V	Hz	kW	r/min	A	cos φ	Duty
370 D	43	200	430	352	0,93	
640 Y	43	200	430	203	0,93	

Prod. code 3GBJ316830-ADG183707

INSULATED BEARINGS AT N-END

	Nmax	r/min
6319/C3	6316M/C3VLO241	1605 kg

IEC 60034-1

Motor sizes 280 to 400

Lubrication plate

ABB

Bearings

6319/C3 6316M/C3VLO241

Regreasing amount

90 g 70 g

Regreasing intervals valid with following running speed and ambient temperature.

430 rpm

40 °C

Regreasing interval in duty hours 3200 h

Grease ESSO UNIREX S2

3GZF194730-75

See respective "Motor Manual"

Motor sizes 500 to 560

ABB **CE** **ABB Oy**
Made in Helsinki, Finland

Type	AMZ 0500LN10 RAM	No	7654321
Year	2004	Phases	3~
Duty	S9, ACS CONVERTER	Output	1468 kW
Connection	Y	Voltage	690 V
Insul.cl.	F	Speed	600 rpm
Weight	6800 kg	Current	1457 A
IP	55	Power factor	0.93
IC	416	Tmax/Tn	1.6
IM	1001		

PERMANENT MAGNET SYNCHRONOUS MACHINE

IEC 60034-1

Motor sizes 500 to 560

Lubrication plate

DRIVE END (DE) BEARING 6330/C3

NON DRIVE END (NDE) BEARING 6330/C3

LUBRICATION INTERVAL 3200 DUTY HOURS

QUANTITY OF GREASE DE 100 GRAMS NDE 100 GRAMS

APPLICABLE GREASES: ESSO UNIREX S2, FAG ARCANOL TEMP110

DELIVERED FROM FACTORY WITH GREASE ESSO UNIREX S2

FOR ADDITIONAL INFORMATION SEE MAINTENANCE MANUAL

Ordering information

When placing an order, please state the following minimum data in the order, as in the example.

The product code of the motor is composed in accordance with the following example.

Motor type M3BJ 280 SMB
 Pole number 12
 Mounting arrangement (IM code) IM B3 (IM 1001)
 Product code if stated 3GBJ316 220-ADG 705
 More variant codes if needed

Motor size

A	B	C	D, E, F, G
M3BJ	280 SMB	3GBJ 316 220	- A D G 705
		1 - 4	5 - 6 7 8 9 10 11 12 13 14 15

- A Motor type
- B Motor size
- C Product code
- D Mounting arrangement code
- E Voltage and frequency code
- F Generation code
- G Variant codes

Explanation of the product code:

Positions 1 to 4

3GBJ = Totally enclosed fan cooled permanent magnet motor with cast iron frame

3GLJ = Totally enclosed water cooled permanent magnet motor with welded steel frame

Positions 5 and 6

IEC-frame

28 = 280
31 = 315
35 = 355
40 = 400

Position 7

Speed (Pole pairs)

6 = 12 poles

Position 8 to 10

Serial number

Position 11

- (dash)

Position 12

Mounting arrangement

A = Foot-mounted, top-mounted terminal box

B = Flange-mounted motors available on request

Position 13

Voltage and frequency code

Network voltage 400 V to 690 V

Position 14

Generation code

C = Liquid cooled motor

G = Air cooled motor

Position 15

Variant codes

705 = 220 r/min at 400 VD/690 VY

706 = 300 r/min at 400 VD/690 VY

707 = 430 r/min at 400 VD/690 VY

708 = 600 r/min at 400 VD/690 VY

Base speed and output depends on the network voltage.

See technical data for values at different network voltages.

The product code must be followed, if needed, by variant codes.

Motors, frame sizes 280 to 400, include variant codes 405, 445 and 701 as standard.

AMZ	0500LS10	RAM
1	2 3 4 5	6 7 8

Explanation of the type designation:

Position 1

Type of machine

Synchronous motor

Position 2

Frame size (shaft height in millimeters)

Always four digits, i.e. 0500 for 500 shaft height

Position 3

Frame length code

Position 4

Stator core length code

Position 5

Number of poles

Position 6

IC/IP combination

J = water jacket IC 71W/IP(55, 56), welded steel frame

R = total enclosed fan cool IC 41(1,6,7)/ IP(55, 56), cast iron frame

Position 7

Bearing type

A = antifriction bearings

Position 8

Type of excitation

M = permanent magnet rotor

All motor characteristics, nominal values and optional features should be specified when placing an order.

Permanent magnet synchronous motors

400 V Technical data

IC 416: Separate cooling or liquid cooled motors

Suitable for constant torque 0 - n_n , constant power n_n - n_{max}

Network voltage 400 V, at motor terminals 370 V

Output kW	Type designation ¹⁾	Product code ¹⁾	Current I_N A	Efficiency Full load ²⁾ %	Torque T_N Nm	Power factor $\cos \varphi$	Torque $\frac{T_{max}}{T_N}$ ⁴⁾	Moment of inertia $J=1/4GD^2$ kgm ²	Maximum speed, n_{max} r/min	Weight approx. kg
$n_n = 127$ r/min										
17	M3_J 280SMB	3G_J286220-_D_183705	34	81.1	1257	0.94	1.0	2.2	152	660
23	M3_J 315SMC	3G_J316230-_D_183705	44	85.4	1720	0.95	1.1	3.9	152	890
36	M3_J 315MLA	3G_J316410-_D_183705	68	86.7	2695	0.95	1.1	5.8	152	1125
45	M3_J 315LKB	3G_J316820-_D_183705	84	87.5	3416	0.97	1.1	7.8	152	1430
58	M3_J 315LKC	3G_J316830-_D_183705	107	89.2	4327	0.95	1.1	9.8	152	1605
63	M3_J 355SMB	3G_J356220-_D_183705	114	88.7	4727	0.97	1.2	17.1	152	1780
86	M3_J 355MLB	3G_J356420-_D_183705	155	89.2	6458	0.97	1.2	22.4	152	2210
100	M3_J 355LKB	3G_J356820-_D_183705	179	90.0	7539	0.97	1.2	28.5	152	2690
126	M3_J 400LC	3G_J406530-_D_183705	221	91.0	9469	0.98	1.1	41.1	152	3280
174	AMZ 0500LE10_AM		310	93.3	13084	0.93	1.2	68	152	5240
237	AMZ 0500LJ10_AM		414	93.9	17822	0.95	1.2	90	152	6020
306	AMZ 0500LN10_AM		533	94.4	23010	0.94	1.2	113	152	6800
386	AMZ 0500LR10_AM		679	94.7	29026	0.93	1.2	135	152	7580
479	AMZ 0560LQ10_AM		832	95.1	36019	0.94	1.3	224	152	10490
576	AMZ 0560LS10_AM		1003	95.4	43313	0.93	1.4	265	152	11480
667	AMZ 0560LU10_AM		1149	95.4	50156	0.94	1.3	306	152	12470
$n_n = 173$ r/min										
23	M3_J 280SMB	3G_J286220-_D_183706	46	85.6	1280	0.93	1.0	2.2	208	660
36	M3_J 315SMC	3G_J316230-_D_183706	68	87.3	1980	0.94	1.0	3.9	208	890
51	M3_J 315MLA	3G_J316410-_D_183706	95	88.9	2835	0.95	1.0	5.8	208	1125
63	M3_J 315LKB	3G_J316820-_D_183706	116	90.8	3496	0.94	1.1	7.8	208	1430
87	M3_J 315LKC	3G_J316830-_D_183706	160	90.8	4774	0.93	1.1	9.8	208	1605
86	M3_J 355SMB	3G_J356220-_D_183706	152	91.2	4760	0.97	1.2	17.1	208	1780
115	M3_J 355MLB	3G_J356420-_D_183706	203	92.0	6360	0.97	1.2	22.4	208	2210
130	M3_J 355LKB	3G_J356820-_D_183706	230	92.9	7154	0.95	1.3	28.5	208	2690
173	M3_J 400LC	3G_J406530-_D_183706	299	93.2	9545	0.97	1.1	41.1	208	3280
238	AMZ 0500LE10_AM		418	94.7	13138	0.93	1.2	68	208	5240
331	AMZ 0500LJ10_AM		576	95.3	18272	0.94	1.2	90	208	6020
432	AMZ 0500LN10_AM		754	95.6	23847	0.93	1.2	113	208	6800
529	AMZ 0500LR10_AM		926	95.9	29202	0.92	1.3	135	208	7580
656	AMZ 0560LQ10_AM		1134	96.2	36213	0.93	1.4	224	208	10490
765	AMZ 0560LS10_AM		1300	96.3	42230	0.95	1.3	265	208	11480
893	AMZ 0560LU10_AM		1516	96.4	49296	0.95	1.3	306	208	12470
$n_n = 220$ r/min										
30	M3_J 280SMB	3G_J286220-_D_183705	58	88.0	1303	0.92	1.0	2.2	264	660
40	M3_J 315SMC	3G_J316230-_D_183705	75	90.5	1743	0.93	1.1	3.9	264	890
63	M3_J 315MLA	3G_J316410-_D_183705	115	91.4	2734	0.93	1.1	5.8	264	1125
80	M3_J 315LKB	3G_J316820-_D_183705	143	91.8	3472	0.95	1.1	7.8	264	1430
100	M3_J 315LKC	3G_J316830-_D_183705	181	92.7	4350	0.93	1.1	9.8	264	1605
110	M3_J 355SMB	3G_J356220-_D_183705	192	92.6	4769	0.96	1.2	17.1	264	1780
150	M3_J 355MLB	3G_J356420-_D_183705	263	92.9	6501	0.96	1.2	22.4	264	2210
175	M3_J 355LKB	3G_J356820-_D_183705	304	93.3	7591	0.96	1.2	28.5	264	2690
220	M3_J 400LC	3G_J406530-_D_183705	375	94.1	9547	0.97	1.1	41.1	264	3280
305	AMZ 0500LE10_AM		534	95.6	13240	0.93	1.2	68	264	5240
428	AMZ 0500LJ10_AM		747	96.1	18579	0.93	1.3	90	264	6020
541	AMZ 0500LN10_AM		933	96.3	23484	0.93	1.2	113	264	6800
668	AMZ 0560LL10_AM		1147	96.6	28997	0.94	1.3	183	264	9500
896	AMZ 0560LR10_AM		1518	96.8	38895	0.95	1.3	245	264	10990
1073	AMZ 0560LT10_AM		1826	96.9	46578	0.94	1.3	286	264	11980

¹⁾ See ordering information - section for details on motor type and product code, variant code 183 used only with air cooled, IC 416 motors
²⁾ Separate cooling fan power not considered in efficiency value

³⁾ Output values and more base speeds for IEC 500 and 560 sizes on request
⁴⁾ T_{max}/T_N value represents maximum short time overloadability with inverter supply. This does not represent the pull-out torque value according to IEC.

Permanent magnet synchronous motors

400 V Technical data

IC 416: Separate cooling or liquid cooled motors

Suitable for constant torque 0 - n_n , constant power n_n - n_{max}

Network voltage 400 V, at motor terminals 370 V

400 V

Output kW	Type designation ¹⁾	Product code ¹⁾	Current I_N A	Efficiency Full load ²⁾ %	Torque T_N Nm	Power factor $\cos \varphi$	Torque $\frac{T_{max}}{T_N}$ ⁴⁾	Moment of inertia $J=1/4GD^2$ kgm ²	Maximum speed, n_{max} r/min	Weight approx. kg
$n_n = 248$ r/min										
32	M3_J 280SMB	3G_J286220-D_183707	59	89.5	1216	0.93	1.0	2.2	298	660
46	M3_J 315SMC	3G_J316230-D_183707	83	91.1	1772	0.95	1.1	3.9	298	890
72	M3_J 315MLA	3G_J316410-D_183707	131	92.2	2776	0.93	1.1	5.8	298	1125
87	M3_J 315LKB	3G_J316820-D_183707	154	93.1	3331	0.94	1.2	7.8	298	1430
116	M3_J 315LKC	3G_J316830-D_183707	205	93.2	4442	0.94	1.1	9.8	298	1605
116	M3_J 355SMB	3G_J356220-D_183707	197	93.1	4441	0.98	1.2	17.1	298	1780
161	M3_J 355MLB	3G_J356420-D_183707	284	94.1	6208	0.94	1.3	22.4	298	2210
193	M3_J 355LKB	3G_J356820-D_183707	331	94.4	7433	0.97	1.3	28.5	298	2690
245	M3_J 400LC	3G_J406530-D_183707	436	95.1	9429	0.92	1.3	41.1	298	3280
332	AMZ 0500LE10_AM		571	96.0	12785	0.94	1.2	68	298	5240
481	AMZ 0500LJ10_AM		834	96.4	18522	0.93	1.2	90	298	6020
619	AMZ 0500LN10_AM		1071	96.6	23836	0.93	1.3	113	298	6800
754	AMZ 0560LL10_AM		1297	96.9	29035	0.93	1.4	183	298	9500
1036	AMZ 0560LR10_AM		1811	97.1	39894	0.93	1.4	245	298	10990
1320	AMZ 0560LU10_AM		2267	97.2	50831	0.93	1.4	306	298	12470
$n_n = 300$ r/min										
41	M3_J 280SMB	3G_J286220-D_183706	77	90.5	1303	0.91	1.0	2.2	360	660
63	M3_J 315SMC	3G_J316230-D_183706	116	91.7	2006	0.92	1.0	3.9	360	890
90	M3_J 315MLA	3G_J316410-D_183706	162	92.8	2864	0.94	1.0	5.8	360	1125
110	M3_J 315LKB	3G_J316820-D_183706	197	93.8	3500	0.93	1.1	7.8	360	1430
150	M3_J 315LKC	3G_J316830-D_183706	271	93.8	4786	0.92	1.1	9.8	360	1605
150	M3_J 355SMB	3G_J356220-D_183706	258	94.0	4769	0.96	1.2	17.1	360	1780
200	M3_J 355MLB	3G_J356420-D_183706	344	94.5	6355	0.96	1.2	22.4	360	2210
225	M3_J 355LKB	3G_J356820-D_183706	393	94.9	7155	0.94	1.3	28.5	360	2690
300	M3_J 400LC	3G_J406530-D_183706	508	95.3	9543	0.97	1.1	41.1	360	3280
417	AMZ 0500LE10_AM		739	96.5	13275	0.92	1.3	68	360	5240
721	AMZ 0500LN10_AM		1227	97.0	22952	0.94	1.3	113	360	6800
895	AMZ 0560LL10_AM		1517	97.2	28491	0.94	1.3	183	360	9500
1342	AMZ 0560LS10_AM		2270	97.4	42720	0.94	1.4	265	360	11480
$n_n = 346$ r/min										
46	M3_J 280SMB	3G_J286220-D_183708	87	91.8	1274	0.91	1.0	2.2	415	660
64	M3_J 315SMC	3G_J316230-D_183708	114	93.2	1750	0.93	1.1	3.9	415	890
92	M3_J 315MLA	3G_J316410-D_183708	161	93.9	2547	0.95	1.1	5.8	415	1125
115	M3_J 315LKB	3G_J316820-D_183708	206	94.7	3180	0.92	1.3	7.8	415	1430
160	M3_J 315LKC	3G_J316830-D_183708	283	94.3	4411	0.94	1.0	9.8	415	1605
161	M3_J 355SMB	3G_J356220-D_183708	276	94.7	4437	0.95	1.2	17.1	415	1780
216	M3_J 355MLB	3G_J356420-D_183708	370	95.2	5966	0.96	1.3	22.4	415	2210
246	M3_J 355LKB	3G_J356820-D_183708	406	95.3	6767	0.99	1.3	28.5	415	2690
323	M3_J 400LC	3G_J406530-D_183708	543	96.0	8908	0.97	1.2	41.1	415	3280
480	AMZ 0500LE10_AM		831	96.8	13249	0.93	1.3	68	415	5240
864	AMZ 0500LN10_AM		1490	97.3	23847	0.92	1.3	113	415	6800
1056	AMZ 0500LR10_AM		1841	97.4	29147	0.92	1.3	135	415	7580
1309	AMZ 0560LQ10_AM		2256	97.6	36130	0.93	1.4	224	415	10490
1503	AMZ 0560LU10_AM		2474	97.9	41485	0.96	1.6	306	415	12470

¹⁾ See ordering information - section for details on motor type and product code, variant code 183 used only with air cooled, IC 416 motors

²⁾ Separate cooling fan power not considered in efficiency value

³⁾ Output values and more base speeds for IEC 500 and 560 sizes on request

⁴⁾ T_{max}/T_N value represents maximum short time overloadability with inverter supply. This does not represent the pull-out torque value according to IEC.

Permanent magnet synchronous motors

400 V Technical data

IC 416: Separate cooling or liquid cooled motors

Suitable for constant torque 0 - n_n , constant power n_n - n_{max}

Network voltage 400 V, at motor terminals 370 V

Output kW	Type designation ¹⁾	Product code ¹⁾	Current I_N A	Efficiency Full load ²⁾ %	Torque T_N Nm	Power factor $\cos \varphi$	Torque $\frac{T_{max}}{T_N}$ ⁴⁾	Moment of inertia $J=1/4GD^2$ kgm ²	Maximum speed, n_{max} r/min	Weight approx. kg
$n_n = 430$ r/min										
55	M3_J 280SMB	3G_J286220-_D_183707	101	92.7	1222	0.92	1.0	2.2	516	660
80	M3_J 315SMC	3G_J316230-_D_183707	141	93.8	1776	0.94	1.1	3.9	516	890
125	M3_J 315MLA	3G_J316410-_D_183707	223	94.5	2775	0.93	1.1	5.8	516	1125
150	M3_J 315LKB	3G_J316820-_D_183707	263	95.0	3329	0.94	1.2	7.8	516	1430
200	M3_J 315LKC	3G_J316830-_D_183707	351	95.1	4440	0.94	1.1	9.8	516	1605
200	M3_J 355SMB	3G_J356220-_D_183707	335	95.1	4440	0.98	1.2	17.1	516	1780
280	M3_J 355MLB	3G_J356420-_D_183707	487	95.6	6207	0.94	1.3	22.4	516	2210
335	M3_J 355LKB	3G_J356820-_D_183707	567	95.8	7434	0.96	1.3	28.5	516	2690
423	M3_J 400LC	3G_J406530-_D_183707	748	96.4	9384	0.92	1.3	41.1	516	3280
596	AMZ 0500LE10 _AM		1053	97.2	13237	0.92	1.3	68	516	5240
834	AMZ 0500LJ10 _AM		1472	97.4	18523	0.92	1.3	90	516	6020
1071	AMZ 0500LN10 _AM		1846	97.5	23786	0.92	1.3	113	516	6800
1298	AMZ 0560LL10 _AM		2250	97.7	28828	0.93	1.4	183	516	9500
1502	AMZ 0560LR10 _AM		2495	98.0	33358	0.95	1.6	245	516	10990
$n_n = 600$ r/min										
80	M3_J 280SMB	3G_J286220-_D_183708	148	94.1	1274	0.90	1.0	2.2	720	660
110	M3_J 315SMC	3G_J316230-_D_183708	195	95.1	1750	0.93	1.1	3.9	720	890
160	M3_J 315MLA	3G_J316410-_D_183708	276	95.5	2546	0.95	1.1	5.8	720	1125
200	M3_J 315LKB	3G_J316820-_D_183708	355	95.8	3179	0.92	1.3	7.8	720	1430
250	M3_J 315LKC	3G_J316830-_D_183708	427	95.9	3977	0.95	1.2	9.8	720	1605
250	M3_J 355SMB	3G_J356220-_D_183708	424	96.0	3974	0.96	1.4	17.1	720	1780
375	M3_J 355MLB	3G_J356420-_D_183708	638	96.2	5963	0.95	1.3	22.4	720	2210
425	M3_J 355LKB	3G_J356820-_D_183708	696	96.2	6763	0.99	1.3	28.5	720	2690
560	M3_J 400LC	3G_J406530-_D_183708	934	96.9	8904	0.97	1.2	41.1	720	3280
³⁾	AMZ 0500L_10 _AM									
³⁾	AMZ 0560L_10 _AM									

¹⁾ See ordering information - section for details on motor type and product code, variant code 183 used only with air cooled, IC 416 motors
²⁾ Separate cooling fan power not considered in efficiency value

³⁾ Output values and more base speeds for IEC 500 and 560 sizes on request
⁴⁾ T_{max}/T_N value represents maximum short time overloadability with inverter supply. This does not represent the pull-out torque value according to IEC.

Permanent magnet synchronous motors

460 V Technical data

IC 416: Separate cooling or liquid cooled motors

Suitable for constant torque 0 - n_n , constant power n_n - n_{max}

Network voltage 460 V, at motor terminals 426 V

Output kW	Type designation ¹⁾	Product code ¹⁾	Current I_N A	Efficiency Full load ²⁾ %	Torque T_N Nm	Power factor $\cos \varphi$	Torque $\frac{T_{max}}{T_N}$ ⁴⁾	Moment of inertia $J=1/4GD^2$ kgm ²	Maximum speed, n_{max} r/min	Weight approx. kg
$n_n = 146$ r/min										
20	M3_J 280SMB	3G_J286220-_D_183705	34	83.0	1277	0.94	1.0	2.2	175	660
27	M3_J 315SMC	3G_J316230-_D_183705	44	86.9	1735	0.94	1.1	3.9	175	890
42	M3_J 315MLA	3G_J316410-_D_183705	68	88.1	2718	0.95	1.1	5.8	175	1125
53	M3_J 315LKB	3G_J316820-_D_183705	84	88.9	3448	0.96	1.1	7.8	175	1430
67	M3_J 315LKC	3G_J316830-_D_183705	106	90.2	4352	0.94	1.1	9.8	175	1605
73	M3_J 355SMB	3G_J356220-_D_183705	113	89.9	4761	0.97	1.2	17.1	175	1780
99	M3_J 355MLB	3G_J356420-_D_183705	155	90.3	6500	0.97	1.2	22.4	175	2210
116	M3_J 355LKB	3G_J356820-_D_183705	179	91.0	7586	0.97	1.2	28.5	175	2690
146	M3_J 400LC	3G_J406530-_D_183705	221	92.0	9528	0.98	1.1	41.1	175	3280
201	AMZ 0500LE10 _AM		310	94.0	13148	0.93	1.2	68	175	5240
274	AMZ 0500LJ10 _AM		414	94.6	17923	0.94	1.2	90	175	6020
353	AMZ 0500LN10 _AM		532	95.0	23090	0.94	1.2	113	175	6800
446	AMZ 0500LR10 _AM		680	95.3	29173	0.93	1.2	135	175	7580
553	AMZ 0560LQ10 _AM		832	95.6	36172	0.94	1.3	224	175	10490
662	AMZ 0560LS10 _AM		1000	95.9	43302	0.93	1.4	265	175	11480
770	AMZ 0560LU10 _AM		1149	95.9	50366	0.94	1.3	306	175	12470
$n_n = 199$ r/min										
27	M3_J 280SMB	3G_J286220-_D_183706	45	87.1	1292	0.93	1.0	2.2	239	660
42	M3_J 315SMC	3G_J316230-_D_183706	68	88.7	1996	0.93	1.0	3.9	239	890
60	M3_J 315MLA	3G_J316410-_D_183706	95	90.2	2854	0.94	1.0	5.8	239	1125
73	M3_J 315LKB	3G_J316820-_D_183706	115	91.7	3502	0.94	1.1	7.8	239	1430
100	M3_J 315LKC	3G_J316830-_D_183706	159	91.7	4788	0.93	1.1	9.8	239	1605
100	M3_J 355SMB	3G_J356220-_D_183706	151	92.1	4775	0.97	1.2	17.1	239	1780
133	M3_J 355MLB	3G_J356420-_D_183706	201	92.7	6363	0.97	1.2	22.4	239	2210
149	M3_J 355LKB	3G_J356820-_D_183706	229	93.6	7151	0.95	1.3	28.5	239	2690
199	M3_J 400LC	3G_J406530-_D_183706	297	93.9	9548	0.97	1.1	41.1	239	3280
275	AMZ 0500LE10 _AM		418	95.2	13197	0.93	1.2	68	239	5240
382	AMZ 0500LJ10 _AM		576	95.8	18332	0.93	1.2	90	239	6020
497	AMZ 0500LN10 _AM		751	96.1	23851	0.93	1.2	113	239	6800
608	AMZ 0500LR10 _AM		922	96.3	29178	0.92	1.3	135	239	7580
754	AMZ 0560LQ10 _AM		1130	96.6	36184	0.93	1.4	224	239	10490
884	AMZ 0560LS10 _AM		1302	96.6	42423	0.95	1.3	265	239	11480
1031	AMZ 0560LU10 _AM		1517	96.7	49478	0.95	1.3	306	239	12470
$n_n = 253$ r/min										
35	M3_J 280SMB	3G_J286220-_D_183705	57	89.1	1303	0.92	1.0	2.2	304	660
46	M3_J 315SMC	3G_J316230-_D_183705	74	91.3	1742	0.92	1.1	3.9	304	890
72	M3_J 315MLA	3G_J316410-_D_183705	115	92.1	2733	0.93	1.1	5.8	304	1125
92	M3_J 315LKB	3G_J316820-_D_183705	141	92.6	3466	0.95	1.1	7.8	304	1430
115	M3_J 315LKC	3G_J316830-_D_183705	179	93.4	4325	0.93	1.1	9.8	304	1605
126	M3_J 355SMB	3G_J356220-_D_183705	191	93.2	4750	0.96	1.2	17.1	304	1780
172	M3_J 355MLB	3G_J356420-_D_183705	261	93.5	6484	0.96	1.2	22.4	304	2210
200	M3_J 355LKB	3G_J356820-_D_183705	300	93.9	7530	0.96	1.2	28.5	304	2690
252	M3_J 400LC	3G_J406530-_D_183705	371	94.7	9495	0.97	1.1	41.1	304	3280
351	AMZ 0500LE10 _AM		532	96.1	13249	0.93	1.3	68	304	5240
493	AMZ 0500LJ10 _AM		746	96.5	18609	0.92	1.3	90	304	6020
705	AMZ 0500LQ10 _AM		1064	96.8	26612	0.92	1.3	124	304	7190
865	AMZ 0560LN10 _AM		1295	97.0	32651	0.93	1.4	203	304	10000
1031	AMZ 0560LR10 _AM		1514	97.1	38917	0.95	1.3	245	304	10990
1237	AMZ 0560LT10 _AM		1826	97.2	46693	0.94	1.4	286	304	11980

¹⁾ See ordering information - section for details on motor type and product code, variant code 183 used only with air cooled, IC416 motors

²⁾ Separate cooling fan power not considered in efficiency value

³⁾ Output values and more base speeds for IEC 500 and 560 sizes on request

⁴⁾ T_{max}/T_N value represents maximum short time overloadability with inverter supply. This does not represent the pull-out torque value according to IEC.

Permanent magnet synchronous motors

460 V Technical data

IC 416: Separate cooling or liquid cooled motors

Suitable for constant torque 0 - n_n , constant power n_n - n_{max}

Network voltage 460 V, at motor terminals 426 V

Output kW	Type designation ¹⁾	Product code ¹⁾	Current I_N A	Efficiency Full load ²⁾ %	Torque T_N Nm	Power factor $\cos \varphi$	Torque $\frac{T_{max}}{T_N}$ ⁴⁾	Moment of inertia $J=1/4GD^2$ kgm ²	Maximum speed, n_{max} r/min	Weight approx. kg
$n_n = 286$ r/min										
37	M3_J 280SMB	3G_J286220-_D_183707	59	90.6	1222	0.93	1.0	2.2	343	660
53	M3_J 315SMC	3G_J316230-_D_183707	83	91.9	1777	0.95	1.1	3.9	343	890
83	M3_J 315MLA	3G_J316410-_D_183707	130	92.9	2775	0.93	1.1	5.8	343	1125
100	M3_J 315LKB	3G_J316820-_D_183707	153	93.8	3331	0.94	1.2	7.8	343	1430
133	M3_J 315LKC	3G_J316830-_D_183707	204	93.8	4441	0.94	1.1	9.8	343	1605
133	M3_J 355SMB	3G_J356220-_D_183707	196	93.7	4441	0.98	1.2	17.1	343	1780
186	M3_J 355MLB	3G_J356420-_D_183707	283	94.6	6207	0.94	1.3	22.4	343	2210
222	M3_J 355LKB	3G_J356820-_D_183707	329	94.8	7430	0.97	1.3	28.5	343	2690
282	M3_J 400LC	3G_J406530-_D_183707	435	95.5	9427	0.92	1.3	41.1	343	3280
383	AMZ 0500LE10 _AM		570	96.3	12789	0.94	1.2	68	343	5240
553	AMZ 0500LJ10 _AM		830	96.7	18466	0.93	1.3	90	343	6020
712	AMZ 0500LN10 _AM		1067	96.9	23775	0.93	1.3	113	343	6800
869	AMZ 0560LL10 _AM		1295	97.1	29017	0.93	1.4	183	343	9500
1193	AMZ 0560LR10 _AM		1809	97.3	39836	0.93	1.4	245	343	10990
1520	AMZ 0560LU10 _AM		2263	97.5	50755	0.93	1.4	306	343	12470
$n_n = 345$ r/min										
47	M3_J 280SMB	3G_J286220-_D_183706	77	91.5	1303	0.91	1.0	2.2	414	660
72	M3_J 315SMC	3G_J316230-_D_183706	115	92.5	2002	0.92	1.0	3.9	414	890
103	M3_J 315MLA	3G_J316410-_D_183706	160	93.5	2850	0.94	1.0	5.8	414	1125
125	M3_J 315LKB	3G_J316820-_D_183706	194	94.3	3457	0.93	1.1	7.8	414	1430
171	M3_J 315LKC	3G_J316830-_D_183706	267	94.3	4735	0.92	1.1	9.8	414	1605
171	M3_J 355SMB	3G_J356220-_D_183706	255	94.5	4729	0.96	1.2	17.1	414	1780
227	M3_J 355MLB	3G_J356420-_D_183706	339	94.9	6295	0.96	1.2	22.4	414	2210
252	M3_J 355LKB	3G_J356820-_D_183706	382	95.3	6976	0.94	1.3	28.5	414	2690
342	M3_J 400LC	3G_J406530-_D_183706	501	95.7	9454	0.97	1.1	41.1	414	3280
553	AMZ 0500LG10 _AM		819	97.0	15308	0.94	1.3	79	414	5630
829	AMZ 0500LN10 _AM		1223	97.3	22948	0.94	1.3	113	414	6800
1029	AMZ 0560LL10 _AM		1513	97.4	28484	0.94	1.4	183	414	9500
1543	AMZ 0560LS10 _AM		2264	97.6	42712	0.94	1.4	265	414	11480
$n_n = 398$ r/min										
53	M3_J 280SMB	3G_J286220-_D_183708	86	92.5	1274	0.90	1.0	2.2	478	660
73	M3_J 315SMC	3G_J316230-_D_183708	113	93.8	1750	0.93	1.1	3.9	478	890
106	M3_J 315MLA	3G_J316410-_D_183708	160	94.3	2546	0.95	1.1	5.8	478	1125
133	M3_J 315LKB	3G_J316820-_D_183708	205	95.1	3179	0.92	1.3	7.8	478	1430
180	M3_J 315LKC	3G_J316830-_D_183708	276	94.8	4314	0.94	1.1	9.8	478	1605
183	M3_J 355SMB	3G_J356220-_D_183708	278	95.2	4386	0.95	1.3	17.1	478	1780
249	M3_J 355MLB	3G_J356420-_D_183708	370	95.6	5965	0.96	1.3	22.4	478	2210
282	M3_J 355LKB	3G_J356820-_D_183708	404	95.6	6766	0.99	1.3	28.5	478	2690
372	M3_J 400LC	3G_J406530-_D_183708	541	96.3	8906	0.97	1.2	41.1	478	3280
552	AMZ 0500LE10 _AM		829	97.0	13245	0.92	1.3	68	478	5240
992	AMZ 0500LN10 _AM		1484	97.5	23803	0.92	1.3	113	478	6800
1213	AMZ 0500LR10 _AM		1839	97.6	29105	0.92	1.3	135	478	7580
1504	AMZ 0560LQ10 _AM		2253	97.7	36088	0.93	1.4	224	478	10490
1730	AMZ 0560LU10 _AM		2472	98.0	41511	0.96	1.6	306	478	12470

¹⁾ See ordering information - section for details on motor type and product code, variant code 183 used only with air cooled, IC416 motors
²⁾ Separate cooling fan power not considered in efficiency value

³⁾ Output values and more base speeds for IEC 500 and 560 sizes on request
⁴⁾ T_{max}/T_N value represents maximum short time overloadability with inverter supply. This does not represent the pull-out torque value according to IEC.

Permanent magnet synchronous motors

460 V Technical data

IC 416: Separate cooling or liquid cooled motors

Suitable for constant torque 0 - n_n , constant power $n_n - n_{max}$

Network voltage 460 V, at motor terminals 426 V

Output kW	Type designation ¹⁾	Product code ¹⁾	Current I_N A	Efficiency Full load ²⁾ %	Torque T_N Nm	Power factor $\cos \varphi$	Torque $\frac{T_{max}}{T_N^{4)}$	Moment of inertia $J=1/4GD^2$ kgm ²	Maximum speed, n_{max} r/min	Weight approx. kg
$n_n = 495$ r/min										
63	M3_J 280SMB	3G_J286220-_D_183707	100	93.4	1211	0.92	1.0	2.2	594	660
91	M3_J 315SMC	3G_J316230-_D_183707	139	94.3	1753	0.94	1.1	3.9	594	890
142	M3_J 315MLA	3G_J316410-_D_183707	219	95.0	2732	0.93	1.1	5.8	594	1125
169	M3_J 315LKB	3G_J316820-_D_183707	257	95.4	3259	0.94	1.2	7.8	594	1430
225	M3_J 315LKC	3G_J316830-_D_183707	341	95.4	4338	0.94	1.1	9.8	594	1605
225	M3_J 355SMB	3G_J356220-_D_183707	325	95.4	4338	0.98	1.2	17.1	594	1780
312	M3_J 355MLB	3G_J356420-_D_183707	472	95.9	6029	0.94	1.3	22.4	594	2210
372	M3_J 355LKB	3G_J356820-_D_183707	545	96.0	7174	0.96	1.3	28.5	594	2690
466	M3_J 400LC	3G_J406530-_D_183707	716	96.6	8997	0.92	1.3	41.1	594	3280
683	AMZ 0500LE10 _AM		1048	97.4	13177	0.92	1.3	68	594	5240
955	AMZ 0500LJ10 _AM		1464	97.6	18425	0.92	1.3	90	594	6020
1227	AMZ 0500LN10 _AM		1834	97.7	23672	0.92	1.3	113	594	6800
1488	AMZ 0560LL10 _AM		2240	97.8	28708	0.93	1.4	183	594	9500
1730	AMZ 0560LR10 _AM		2495	98.0	33377	0.95	1.6	245	594	10990
$n_n = 690$ r/min										
90	M3_J 280SMB	3G_J286220-_D_183708	145	94.6	1248	0.90	1.1	2.2	828	660
123	M3_J 315SMC	3G_J316230-_D_183708	188	95.3	1699	0.93	1.2	3.9	828	890
179	M3_J 315MLA	3G_J316410-_D_183708	267	95.7	2478	0.95	1.1	5.8	828	1125
221	M3_J 315LKB	3G_J316820-_D_183708	340	96.0	3052	0.92	1.3	7.8	828	1430
277	M3_J 315LKC	3G_J316830-_D_183708	409	96.1	3826	0.96	1.2	9.8	828	1605
272	M3_J 355SMB	3G_J356220-_D_183708	402	96.1	3769	0.96	1.5	17.1	828	1780
414	M3_J 355MLB	3G_J356420-_D_183708	610	96.4	5724	0.95	1.4	22.4	828	2210
468	M3_J 355LKB	3G_J356820-_D_183708	664	96.4	6479	0.99	1.3	28.5	828	2690
623	M3_J 400LC	3G_J406530-_D_183708	900	97.0	8615	0.97	1.3	41.1	828	3280
³⁾	AMZ 0500L_10 _AM									
³⁾	AMZ 0560L_10 _AM									

¹⁾ See ordering information - section for details on motor type and product code, variant code 183 used only with air cooled, IC416 motors

²⁾ Separate cooling fan power not considered in efficiency value

³⁾ Output values and more base speeds for IEC 500 and 560 sizes on request

⁴⁾ T_{max}/T_N value represents maximum short time overloadability with inverter supply. This does not represent the pull-out torque value according to IEC.

Permanent magnet synchronous motors

500 V Technical data

IC 416: Separate cooling or liquid cooled motors

Suitable for constant torque 0 - n_n , constant power n_n - n_{max}

Network voltage 500 V, at motor terminals 463 V

Output kW	Type designation ¹⁾	Product code ¹⁾	Current I_N A	Efficiency Full load ²⁾ %	Torque T_N Nm	Power factor $\cos \varphi$	Torque $\frac{T_{max}}{T_N}$ ⁴⁾	Moment of inertia $J=1/4GD^2$ kgm ²	Maximum speed, n_{max} r/min	Weight approx. kg
$n_n = 159$ r/min										
21	M3_J 280SMB	3G_J286220-_D_183705	34	84.3	1287	0.93	1.0	2.2	191	660
29	M3_J 315SMC	3G_J316230-_D_183705	44	87.9	1742	0.94	1.1	3.9	191	890
45	M3_J 315MLA	3G_J316410-_D_183705	68	88.8	2730	0.94	1.1	5.8	191	1125
58	M3_J 315LKB	3G_J316820-_D_183705	84	89.6	3463	0.96	1.1	7.8	191	1430
72	M3_J 315LKC	3G_J316830-_D_183705	106	90.8	4352	0.94	1.1	9.8	191	1605
79	M3_J 355SMB	3G_J356220-_D_183705	113	90.5	4775	0.97	1.2	17.1	191	1780
108	M3_J 355MLB	3G_J356420-_D_183705	154	90.9	6510	0.96	1.2	22.4	191	2210
126	M3_J 355LKB	3G_J356820-_D_183705	178	91.6	7596	0.97	1.2	28.5	191	2690
159	M3_J 400LC	3G_J406530-_D_183705	220	92.5	9550	0.97	1.1	41.1	191	3280
219	AMZ 0500LE10_AM		310	94.4	13154	0.93	1.2	68	191	5240
299	AMZ 0500LJ10_AM		415	94.9	17959	0.94	1.2	90	191	6020
385	AMZ 0500LN10_AM		533	95.3	23124	0.94	1.2	113	191	6800
486	AMZ 0500LR10_AM		680	95.6	29191	0.93	1.2	135	191	7580
602	AMZ 0560LQ10_AM		831	95.9	36158	0.94	1.3	224	191	10490
721	AMZ 0560LS10_AM		1000	96.1	43305	0.93	1.4	265	191	11480
839	AMZ 0560LU10_AM		1149	96.1	50393	0.94	1.3	306	191	12470
$n_n = 217$ r/min										
29	M3_J 280SMB	3G_J286220-_D_183706	45	87.8	1299	0.92	1.0	2.2	260	660
45	M3_J 315SMC	3G_J316230-_D_183706	68	89.4	2004	0.93	1.0	3.9	260	890
65	M3_J 315MLA	3G_J316410-_D_183706	95	90.8	2864	0.94	1.0	5.8	260	1125
79	M3_J 315LKB	3G_J316820-_D_183706	115	92.2	3501	0.94	1.1	7.8	260	1430
109	M3_J 315LKC	3G_J316830-_D_183706	158	92.1	4787	0.93	1.1	9.8	260	1605
108	M3_J 355SMB	3G_J356220-_D_183706	151	92.6	4774	0.97	1.2	17.1	260	1780
144	M3_J 355MLB	3G_J356420-_D_183706	201	93.2	6361	0.96	1.2	22.4	260	2210
162	M3_J 355LKB	3G_J356820-_D_183706	228	93.9	7150	0.95	1.3	28.5	260	2690
217	M3_J 400LC	3G_J406530-_D_183706	296	94.3	9547	0.97	1.1	41.1	260	3280
299	AMZ 0500LE10_AM		417	95.5	13159	0.93	1.2	68	260	5240
416	AMZ 0500LJ10_AM		576	96.0	18308	0.93	1.2	90	260	6020
541	AMZ 0500LN10_AM		750	96.3	23809	0.93	1.2	113	260	6800
665	AMZ 0500LR10_AM		927	96.5	29266	0.92	1.3	135	260	7580
825	AMZ 0560LQ10_AM		1135	96.7	36308	0.93	1.4	224	260	10490
961	AMZ 0560LS10_AM		1299	96.8	42293	0.95	1.3	265	260	11480
1121	AMZ 0560LU10_AM		1514	96.9	49334	0.95	1.3	306	260	12470
$n_n = 275$ r/min										
38	M3_J 280SMB	3G_J286220-_D_183705	57	89.7	1303	0.91	1.0	2.2	330	660
50	M3_J 315SMC	3G_J316230-_D_183705	74	91.9	1729	0.92	1.1	3.9	330	890
78	M3_J 315MLA	3G_J316410-_D_183705	113	92.7	2715	0.93	1.1	5.8	330	1125
99	M3_J 315LKB	3G_J316820-_D_183705	140	93.1	3442	0.95	1.1	7.8	330	1430
123	M3_J 315LKC	3G_J316830-_D_183705	177	93.8	4280	0.93	1.2	9.8	330	1605
136	M3_J 355SMB	3G_J356220-_D_183705	188	93.5	4707	0.96	1.2	17.1	330	1780
185	M3_J 355MLB	3G_J356420-_D_183705	257	93.9	6422	0.96	1.2	22.4	330	2210
215	M3_J 355LKB	3G_J356820-_D_183705	295	94.2	7449	0.96	1.2	28.5	330	2690
271	M3_J 400LC	3G_J406530-_D_183705	366	95.0	9404	0.97	1.1	41.1	330	3280
381	AMZ 0500LE10_AM		531	96.3	13231	0.93	1.3	68	330	5240
601	AMZ 0500LL10_AM		826	96.8	20871	0.93	1.3	101	330	6410
765	AMZ 0500LQ10_AM		1060	96.9	26566	0.92	1.3	124	330	7190
1119	AMZ 0560LR10_AM		1510	97.3	38860	0.94	1.3	245	330	10990
1344	AMZ 0560LT10_AM		1824	97.3	46673	0.94	1.4	286	330	11980

¹⁾ See ordering information - section for details on motor type and product code, variant code 183 used only with air cooled, IC416 motors
²⁾ Separate cooling fan power not considered in efficiency value

³⁾ Output values and more base speeds for IEC 500 and 560 sizes on request
⁴⁾ $\frac{T_{max}}{T_N}$ value represents maximum short time overloadability with inverter supply. This does not represent the pull-out torque value according to IEC.



Permanent magnet synchronous motors

500 V Technical data

IC 416: Separate cooling or liquid cooled motors

Suitable for constant torque 0 - n_n , constant power n_n - n_{max}

Network voltage 500 V, at motor terminals 463 V

Output kW	Type designation ¹⁾	Product code ¹⁾	Current I_N A	Efficiency Full load ²⁾ %	Torque T_N Nm	Power factor $\cos \varphi$	Torque $\frac{T_{max}}{T_N}$ ⁴⁾	Moment of inertia $J=1/4GD^2$ kgm ²	Maximum speed, n_{max} r/min	Weight approx. kg
$n_n = 310$ r/min										
40	M3_J 280SMB	3G_J286220-D_183707	59	91.1	1222	0.92	1.0	2.2	372	660
58	M3_J 315SMC	3G_J316230-D_183707	83	92.3	1777	0.95	1.1	3.9	372	890
90	M3_J 315MLA	3G_J316410-D_183707	130	93.3	2775	0.93	1.1	5.8	372	1125
108	M3_J 315LKB	3G_J316820-D_183707	153	94.1	3330	0.94	1.2	7.8	372	1430
144	M3_J 315LKC	3G_J316830-D_183707	204	94.1	4440	0.94	1.1	9.8	372	1605
144	M3_J 355SMB	3G_J356220-D_183707	195	94.1	4440	0.98	1.2	17.1	372	1780
202	M3_J 355MLB	3G_J356420-D_183707	282	94.9	6206	0.94	1.3	22.4	372	2210
241	M3_J 355LKB	3G_J356820-D_183707	329	95.1	7429	0.96	1.3	28.5	372	2690
306	M3_J 400LC	3G_J406530-D_183707	435	95.7	9427	0.92	1.3	41.1	372	3280
416	AMZ 0500LE10_AM		570	96.5	12815	0.94	1.2	68	372	5240
602	AMZ 0500LJ10_AM		832	96.9	18545	0.93	1.3	90	372	6020
774	AMZ 0500LN10_AM		1068	97.1	23844	0.93	1.3	113	372	6800
941	AMZ 0560LL10_AM		1293	97.3	28989	0.93	1.4	183	372	9500
1293	AMZ 0560LR10_AM		1809	97.5	39833	0.93	1.4	245	372	10990
1647	AMZ 0560LU10_AM		2263	97.6	50738	0.93	1.4	306	372	12470
$n_n = 375$ r/min										
51	M3_J 280SMB	3G_J286220-D_183706	77	91.9	1303	0.91	1.0	2.2	450	660
78	M3_J 315SMC	3G_J316230-D_183706	114	92.9	1987	0.92	1.0	3.9	450	890
111	M3_J 315MLA	3G_J316410-D_183706	158	93.7	2825	0.94	1.0	5.8	450	1125
134	M3_J 315LKB	3G_J316820-D_183706	190	94.6	3409	0.93	1.2	7.8	450	1430
184	M3_J 315LKC	3G_J316830-D_183706	263	94.5	4676	0.92	1.1	9.8	450	1605
183	M3_J 355SMB	3G_J356220-D_183706	250	94.7	4664	0.96	1.2	17.1	450	1780
243	M3_J 355MLB	3G_J356420-D_183706	333	95.1	6197	0.96	1.2	22.4	450	2210
268	M3_J 355LKB	3G_J356820-D_183706	373	95.4	6826	0.94	1.4	28.5	450	2690
366	M3_J 400LC	3G_J406530-D_183706	491	95.9	9309	0.97	1.2	41.1	450	3280
520	AMZ 0500LE10_AM		737	97.0	13243	0.92	1.3	68	450	5240
900	AMZ 0500LN10_AM		1221	97.4	22920	0.94	1.3	113	450	6800
1116	AMZ 0560LL10_AM		1508	97.5	28421	0.94	1.4	183	450	9500
1673	AMZ 0560LS10_AM		2256	97.7	42606	0.94	1.4	265	450	11480
$n_n = 433$ r/min										
58	M3_J 280SMB	3G_J286220-D_183708	86	92.9	1274	0.90	1.0	2.2	520	660
79	M3_J 315SMC	3G_J316230-D_183708	113	94.2	1750	0.93	1.1	3.9	520	890
116	M3_J 315MLA	3G_J316410-D_183708	160	94.7	2546	0.95	1.1	5.8	520	1125
144	M3_J 315LKB	3G_J316820-D_183708	205	95.3	3179	0.92	1.3	7.8	520	1430
196	M3_J 315LKC	3G_J316830-D_183708	273	95.1	4322	0.94	1.1	9.8	520	1605
200	M3_J 355SMB	3G_J356220-D_183708	275	95.4	4415	0.95	1.3	17.1	520	1780
270	M3_J 355MLB	3G_J356420-D_183708	369	95.7	5964	0.96	1.3	22.4	520	2210
307	M3_J 355LKB	3G_J356820-D_183708	404	95.8	6765	0.99	1.3	28.5	520	2690
404	M3_J 400LC	3G_J406530-D_183708	541	96.4	8906	0.97	1.2	41.1	520	3280
599	AMZ 0500LE10_AM		827	97.2	13211	0.92	1.3	68	520	5240
1077	AMZ 0500LN10_AM		1481	97.6	23754	0.92	1.3	113	520	6800
1316	AMZ 0500LR10_AM		1833	97.6	29025	0.92	1.3	135	520	7580
1631	AMZ 0560LQ10_AM		2245	97.8	35972	0.93	1.4	224	520	10490
1881	AMZ 0560LU10_AM		2471	98.0	41486	0.96	1.6	306	520	12470

¹⁾ See ordering information - section for details on motor type and product code, variant code 183 used only with air cooled, IC 416 motors

²⁾ Separate cooling fan power not considered in efficiency value

³⁾ Output values and more base speeds for IEC 500 and 560 sizes on request

⁴⁾ T_{max}/T_N value represents maximum short time overloadability with inverter supply. This does not represent the pull-out torque value according to IEC.

Permanent magnet synchronous motors

500 V Technical data

IC 416: Separate cooling or liquid cooled motors

Suitable for constant torque 0 - n_n , constant power n_n - n_{max}

Network voltage 500 V, at motor terminals 463 V

Output kW	Type designation ¹⁾	Product code ¹⁾	Current I_N A	Efficiency Full load ²⁾ %	Torque T_N Nm	Power factor $\cos \varphi$	Torque $\frac{T_{max}}{T_N}$ ⁴⁾	Moment of inertia $J=1/4GD^2$ kgm ²	Maximum speed, n_{max} r/min	Weight approx. kg
$n_n = 538$ r/min										
67	M3_J 280SMB	3G_J286220-_D_183707	98	93.7	1196	0.92	1.1	2.2	646	660
97	M3_J 315SMC	3G_J316230-_D_183707	136	94.6	1727	0.94	1.1	3.9	646	890
151	M3_J 315MLA	3G_J316410-_D_183707	214	95.2	2684	0.93	1.1	5.8	646	1125
179	M3_J 315LKB	3G_J316820-_D_183707	250	95.5	3185	0.94	1.2	7.8	646	1430
239	M3_J 315LKC	3G_J316830-_D_183707	333	95.6	4245	0.94	1.2	9.8	646	1605
239	M3_J 355SMB	3G_J356220-_D_183707	318	95.6	4247	0.98	1.3	17.1	646	1780
330	M3_J 355MLB	3G_J356420-_D_183707	458	96.0	5858	0.94	1.4	22.4	646	2210
392	M3_J 355LKB	3G_J356820-_D_183707	528	96.1	6961	0.96	1.4	28.5	646	2690
491	M3_J 400LC	3G_J406530-_D_183707	693	96.7	8727	0.92	1.4	41.1	646	3280
741	AMZ 0500LE10 _AM		1046	97.4	13153	0.92	1.3	68	646	5240
1035	AMZ 0500LJ10 _AM		1459	97.6	18372	0.92	1.3	90	646	6020
1330	AMZ 0500LN10 _AM		1828	97.8	23609	0.92	1.3	113	646	6800
1612	AMZ 0560LL10 _AM		2233	97.9	28614	0.93	1.4	183	646	9500
1881	AMZ 0560LR10 _AM		2496	98.1	33389	0.95	1.6	245	646	10990
$n_n = 750$ r/min										
96	M3_J 280SMB	3G_J286220-_D_183708	141	94.7	1223	0.90	1.1	2.2	863	660
130	M3_J 315SMC	3G_J316230-_D_183708	183	95.5	1655	0.93	1.2	3.9	863	890
189	M3_J 315MLA	3G_J316410-_D_183708	259	95.8	2411	0.95	1.2	5.8	863	1125
230	M3_J 315LKB	3G_J316820-_D_183708	326	96.0	2931	0.92	1.4	7.8	863	1430
290	M3_J 315LKC	3G_J316830-_D_183708	393	96.1	3689	0.96	1.3	9.8	863	1605
282	M3_J 355SMB	3G_J356220-_D_183708	383	96.2	3595	0.96	1.6	17.1	863	1780
432	M3_J 355MLB	3G_J356420-_D_183708	585	96.4	5494	0.96	1.4	22.4	863	2210
488	M3_J 355LKB	3G_J356820-_D_183708	636	96.4	6211	0.99	1.4	28.5	863	2690
651	M3_J 400LC	3G_J406530-_D_183708	863	97.1	8288	0.97	1.3	41.1	863	3280
³⁾	AMZ 0500L_10 _AM									
³⁾	AMZ 0560L_10 _AM									

¹⁾ See ordering information - section for details on motor type and product code, variant code 183 used only with air cooled, IC 416 motors
²⁾ Separate cooling fan power not considered in efficiency value

³⁾ Output values and more base speeds for IEC 500 and 560 sizes on request
⁴⁾ T_{max}/T_N value represents maximum short time overloadability with inverter supply. This does not represent the pull-out torque value according to IEC.

Permanent magnet synchronous motors

575 V Technical data

IC 416: Separate cooling or liquid cooled motors

Suitable for constant torque 0 - n_n , constant power n_n - n_{max}

Network voltage 575 V, at motor terminals 532 V

Output kW	Type designation ¹⁾	Product code ¹⁾	Current I_N A	Efficiency Full load ²⁾ %	Torque T_N Nm	Power factor $\cos \varphi$	Torque $\frac{T_{max}}{T_N}$ ⁴⁾	Moment of inertia $J=1/4GD^2$ kgm ²	Maximum speed, n_{max} r/min	Weight approx. kg
$n_n = 183$ r/min										
25	M3_J 280SMB	3G_J286220-_D_183705	34	85.9	1302	0.93	1.0	2.2	220	660
33	M3_J 315SMC	3G_J316230-_D_183705	44	89.0	1744	0.93	1.1	3.9	220	890
52	M3_J 315MLA	3G_J316410-_D_183705	67	90.0	2735	0.94	1.1	5.8	220	1125
66	M3_J 315LKB	3G_J316820-_D_183705	83	90.7	3473	0.96	1.1	7.8	220	1430
83	M3_J 315LKC	3G_J316830-_D_183705	105	91.7	4351	0.94	1.1	9.8	220	1605
91	M3_J 355SMB	3G_J356220-_D_183705	112	91.5	4771	0.97	1.2	17.1	220	1780
124	M3_J 355MLB	3G_J356420-_D_183705	153	91.9	6505	0.96	1.2	22.4	220	2210
145	M3_J 355LKB	3G_J356820-_D_183705	177	92.5	7592	0.97	1.2	28.5	220	2690
183	M3_J 400LC	3G_J406530-_D_183705	218	93.3	9548	0.97	1.1	41.1	220	3280
253	AMZ 0500LE10_AM		310	95.0	13203	0.93	1.2	68	220	5240
344	AMZ 0500LJ10_AM		414	95.5	17952	0.94	1.2	90	220	6020
443	AMZ 0500LN10_AM		531	95.8	23118	0.94	1.2	113	220	6800
560	AMZ 0500LR10_AM		680	96.0	29224	0.93	1.3	135	220	7580
694	AMZ 0560LQ10_AM		831	96.3	36217	0.94	1.3	224	220	10490
833	AMZ 0560LS10_AM		1005	96.5	43471	0.93	1.4	265	220	11480
964	AMZ 0560LU10_AM		1146	96.5	50307	0.94	1.3	306	220	12470
$n_n = 249$ r/min										
34	M3_J 280SMB	3G_J286220-_D_183706	45	89.2	1303	0.92	1.0	2.2	299	660
52	M3_J 315SMC	3G_J316230-_D_183706	68	90.5	2006	0.93	1.0	3.9	299	890
75	M3_J 315MLA	3G_J316410-_D_183706	94	91.8	2864	0.94	1.0	5.8	299	1125
91	M3_J 315LKB	3G_J316820-_D_183706	114	93.0	3500	0.93	1.1	7.8	299	1430
125	M3_J 315LKC	3G_J316830-_D_183706	157	92.9	4786	0.93	1.1	9.8	299	1605
124	M3_J 355SMB	3G_J356220-_D_183706	150	93.3	4771	0.97	1.2	17.1	299	1780
166	M3_J 355MLB	3G_J356420-_D_183706	200	93.8	6359	0.96	1.2	22.4	299	2210
186	M3_J 355LKB	3G_J356820-_D_183706	227	94.4	7147	0.94	1.3	28.5	299	2690
249	M3_J 400LC	3G_J406530-_D_183706	295	94.8	9545	0.97	1.1	41.1	299	3280
345	AMZ 0500LE10_AM		418	96.0	13232	0.93	1.2	68	299	5240
478	AMZ 0500LJ10_AM		575	96.4	18333	0.93	1.2	90	299	6020
622	AMZ 0500LN10_AM		749	96.6	23856	0.93	1.3	113	299	6800
762	AMZ 0500LR10_AM		923	96.8	29225	0.92	1.3	135	299	7580
945	AMZ 0560LQ10_AM		1132	97.0	36244	0.93	1.4	224	299	10490
1104	AMZ 0560LS10_AM		1297	97.1	42342	0.95	1.3	265	299	11480
1288	AMZ 0560LU10_AM		1512	97.2	49399	0.95	1.3	306	299	12470
$n_n = 316$ r/min										
43	M3_J 280SMB	3G_J286220-_D_183705	57	90.9	1303	0.91	1.0	2.2	379	660
56	M3_J 315SMC	3G_J316230-_D_183705	72	92.6	1702	0.92	1.2	3.9	379	890
89	M3_J 315MLA	3G_J316410-_D_183705	111	93.3	2674	0.93	1.1	5.8	379	1125
112	M3_J 315LKB	3G_J316820-_D_183705	137	93.7	3388	0.95	1.1	7.8	379	1430
139	M3_J 315LKC	3G_J316830-_D_183705	172	94.3	4187	0.93	1.2	9.8	379	1605
153	M3_J 355SMB	3G_J356220-_D_183705	184	94.1	4615	0.96	1.2	17.1	379	1780
208	M3_J 355MLB	3G_J356420-_D_183705	251	94.4	6293	0.96	1.2	22.4	379	2210
241	M3_J 355LKB	3G_J356820-_D_183705	287	94.7	7281	0.96	1.2	28.5	379	2690
305	M3_J 400LC	3G_J406530-_D_183705	357	95.4	9215	0.97	1.1	41.1	379	3280
439	AMZ 0500LE10_AM		531	96.6	13267	0.92	1.3	68	379	5240
615	AMZ 0500LJ10_AM		742	96.9	18586	0.92	1.3	90	379	6020
778	AMZ 0500LN10_AM		929	97.1	23512	0.93	1.3	113	379	6800
1078	AMZ 0560LN10_AM		1292	97.4	32579	0.93	1.4	203	379	10000
1286	AMZ 0560LR10_AM		1508	97.5	38865	0.94	1.4	245	379	10990
1543	AMZ 0560LT10_AM		1819	97.5	46632	0.94	1.4	286	379	11980

¹⁾ See ordering information - section for details on motor type and product code, variant code 183 used only with air cooled, IC 416 motors

²⁾ Separate cooling fan power not considered in efficiency value

³⁾ Output values and more base speeds for IEC 500 and 560 sizes on request

⁴⁾ T_{max}/T_N value represents maximum short time overloadability with inverter supply. This does not represent the pull-out torque value according to IEC.

Permanent magnet synchronous motors

575 V Technical data

IC 416: Separate cooling or liquid cooled motors

Suitable for constant torque 0 - n_n , constant power n_n - n_{max}

Network voltage 575 V, at motor terminals 532 V

Output kW	Type designation ¹⁾	Product code ¹⁾	Current I_N A	Efficiency Full load ²⁾ %	Torque T_N Nm	Power factor $\cos \varphi$	Torque $\frac{T_{max}}{T_N}$ ⁴⁾	Moment of inertia $J=1/4GD^2$ kgm ²	Maximum speed, n_{max} r/min	Weight approx. kg
$n_n = 357$ r/min										
46	M3_J 280SMB	3G_J286220-_D_183707	59	92.0	1222	0.92	1.0	2.2	428	660
66	M3_J 315SMC	3G_J316230-_D_183707	82	93.1	1776	0.94	1.1	3.9	428	890
104	M3_J 315MLA	3G_J316410-_D_183707	129	93.8	2775	0.93	1.1	5.8	428	1125
124	M3_J 315LKB	3G_J316820-_D_183707	153	94.5	3330	0.94	1.2	7.8	428	1430
166	M3_J 315LKC	3G_J316830-_D_183707	203	94.6	4440	0.94	1.1	9.8	428	1605
166	M3_J 355SMB	3G_J356220-_D_183707	194	94.5	4439	0.98	1.2	17.1	428	1780
232	M3_J 355MLB	3G_J356420-_D_183707	282	95.2	6205	0.94	1.3	22.4	428	2210
278	M3_J 355LKB	3G_J356820-_D_183707	328	95.4	7427	0.96	1.3	28.5	428	2690
352	M3_J 400LC	3G_J406530-_D_183707	434	96.0	9426	0.92	1.3	41.1	428	3280
478	AMZ 0500LE10 _AM		568	96.8	12787	0.94	1.2	68	428	5240
690	AMZ 0500LJ10 _AM		827	97.1	18458	0.93	1.3	90	428	6020
887	AMZ 0500LN10 _AM		1062	97.3	23728	0.93	1.3	113	428	6800
1080	AMZ 0560LL10 _AM		1289	97.5	28891	0.93	1.4	183	428	9500
1486	AMZ 0560LR10 _AM		1805	97.6	39752	0.93	1.4	245	428	10990
1889	AMZ 0560LU10 _AM		2253	97.7	50532	0.93	1.4	306	428	12470
$n_n = 431$ r/min										
58	M3_J 280SMB	3G_J286220-_D_183706	75	92.6	1279	0.91	1.0	2.2	517	660
88	M3_J 315SMC	3G_J316230-_D_183706	112	93.5	1956	0.92	1.0	3.9	517	890
125	M3_J 315MLA	3G_J316410-_D_183706	154	94.3	2771	0.94	1.1	5.8	517	1125
150	M3_J 315LKB	3G_J316820-_D_183706	184	94.9	3310	0.93	1.2	7.8	517	1430
206	M3_J 315LKC	3G_J316830-_D_183706	255	95.0	4555	0.92	1.1	9.8	517	1605
205	M3_J 355SMB	3G_J356220-_D_183706	242	95.1	4529	0.97	1.3	17.1	517	1780
271	M3_J 355MLB	3G_J356420-_D_183706	321	95.5	5998	0.96	1.3	22.4	517	2210
295	M3_J 355LKB	3G_J356820-_D_183706	356	95.7	6524	0.94	1.4	28.5	517	2690
407	M3_J 400LC	3G_J406530-_D_183706	474	96.2	9019	0.97	1.2	41.1	517	3280
597	AMZ 0500LE10 _AM		737	97.2	13228	0.92	1.3	68	517	5240
1032	AMZ 0500LN10 _AM		1216	97.6	22867	0.94	1.3	113	517	6800
1280	AMZ 0560LL10 _AM		1503	97.7	28362	0.94	1.4	183	517	9500
1917	AMZ 0560LS10 _AM		2247	97.9	42476	0.94	1.4	265	517	11480
$n_n = 498$ r/min										
66	M3_J 280SMB	3G_J286220-_D_183708	86	93.5	1274	0.90	1.0	2.2	598	660
91	M3_J 315SMC	3G_J316230-_D_183708	113	94.5	1750	0.93	1.1	3.9	598	890
133	M3_J 315MLA	3G_J316410-_D_183708	160	95.1	2546	0.95	1.1	5.8	598	1125
166	M3_J 315LKB	3G_J316820-_D_183708	205	95.6	3179	0.92	1.3	7.8	598	1430
207	M3_J 315LKC	3G_J316830-_D_183708	247	95.6	3976	0.95	1.2	9.8	598	1605
207	M3_J 355SMB	3G_J356220-_D_183708	245	95.8	3972	0.96	1.4	17.1	598	1780
311	M3_J 355MLB	3G_J356420-_D_183708	369	96.0	5963	0.95	1.3	22.4	598	2210
353	M3_J 355LKB	3G_J356820-_D_183708	403	96.0	6764	0.99	1.3	28.5	598	2690
464	M3_J 400LC	3G_J406530-_D_183708	540	96.7	8905	0.97	1.2	41.1	598	3280
687	AMZ 0500LE10 _AM		824	97.3	13174	0.92	1.3	68	598	5240
1233	AMZ 0500LN10 _AM		1473	97.7	23645	0.92	1.3	113	598	6800
1506	AMZ 0500LR10 _AM		1823	97.8	28880	0.92	1.3	135	598	7580
1868	AMZ 0560LQ10 _AM		2236	97.9	35822	0.93	1.4	224	598	10490
2163	AMZ 0560LU10 _AM		2472	98.1	41479	0.96	1.6	306	598	12470

¹⁾ See ordering information - section for details on motor type and product code, variant code 183 used only with air cooled, IC 416 motors

²⁾ Separate cooling fan power not considered in efficiency value

³⁾ Output values and more base speeds for IEC 500 and 560 sizes on request

⁴⁾ T_{max}/T_N value represents maximum short time overloadability with inverter supply. This does not represent the pull-out torque value according to IEC.

Permanent magnet synchronous motors

575 V Technical data

IC 416: Separate cooling or liquid cooled motors

Suitable for constant torque 0 - n_n , constant power n_n - n_{max}

Network voltage 575 V, at motor terminals 532 V

Output kW	Type designation ¹⁾	Product code ¹⁾	Current I_N A	Efficiency Full load ²⁾ %	Torque T_N Nm	Power factor $\cos \varphi$	Torque $\frac{T_{max}}{T_N^{4)}$	Moment of inertia $J=1/4GD^2$ kgm ²	Maximum speed, n_{max} r/min	Weight approx. kg
$n_n = 618$ r/min										
75	M3_J 280SMB	3G_J286220-_D_183707	95	94.2	1164	0.92	1.1	2.2	742	660
108	M3_J 315SMC	3G_J316230-_D_183707	131	95.0	1674	0.94	1.2	3.9	742	890
167	M3_J 315MLA	3G_J316410-_D_183707	205	95.4	2586	0.93	1.2	5.8	742	1125
196	M3_J 315LKB	3G_J316820-_D_183707	237	95.7	3033	0.94	1.3	7.8	742	1430
263	M3_J 315LKC	3G_J316830-_D_183707	316	95.8	4056	0.94	1.2	9.8	742	1605
263	M3_J 355SMB	3G_J356220-_D_183707	302	95.8	4062	0.99	1.3	17.1	742	1780
357	M3_J 355MLB	3G_J356420-_D_183707	431	96.2	5517	0.94	1.5	22.4	742	2210
423	M3_J 355LKB	3G_J356820-_D_183707	494	96.3	6536	0.97	1.5	28.5	742	2690
531	M3_J 400LC	3G_J406530-_D_183707	651	96.8	8196	0.91	1.5	41.1	742	3280
847	AMZ 0500LE10 _AM		1040	97.6	13089	0.92	1.3	68	742	5240
1181	AMZ 0500LJ10 _AM		1449	97.7	18250	0.92	1.3	90	742	6020
1518	AMZ 0500LN10 _AM		1813	97.8	23458	0.92	1.3	113	742	6800
1840	AMZ 0560LL10 _AM		2218	98.0	28434	0.93	1.4	183	742	9500
2162	AMZ 0560LR10 _AM		2497	98.1	33410	0.95	1.6	245	742	10990
$n_n = 863$ r/min										
106	M3_J 280SMB	3G_J286220-_D_183708	134	95.0	1171	0.90	1.1	2.2	863	660
142	M3_J 315SMC	3G_J316230-_D_183708	172	95.7	1566	0.93	1.3	3.9	863	890
205	M3_J 315MLA	3G_J316410-_D_183708	242	95.9	2273	0.96	1.2	5.8	863	1125
243	M3_J 315LKB	3G_J316820-_D_183708	299	96.0	2687	0.92	1.5	7.8	863	1430
308	M3_J 315LKC	3G_J316830-_D_183708	362	96.2	3411	0.96	1.4	9.8	863	1605
293	M3_J 355SMB	3G_J356220-_D_183708	346	96.1	3247	0.96	1.8	17.1	863	1780
455	M3_J 355MLB	3G_J356420-_D_183708	534	96.4	5033	0.96	1.5	22.4	863	2210
513	M3_J 355LKB	3G_J356820-_D_183708	579	96.4	5675	1.00	1.5	28.5	863	2690
691	M3_J 400LC	3G_J406530-_D_183708	792	97.1	7645	0.98	1.4	41.1	863	3280
³⁾	AMZ 0500L_10 _AM									
³⁾	AMZ 0560L_10 _AM									

¹⁾ See ordering information - section for details on motor type and product code, variant code 183 used only with air cooled, IC 416 motors

²⁾ Separate cooling fan power not considered in efficiency value

³⁾ Output values and more base speeds for IEC 500 and 560 sizes on request

⁴⁾ T_{max}/T_N value represents maximum short time overloadability with inverter supply. This does not represent the pull-out torque value according to IEC.

Permanent magnet synchronous motors

690 V Technical data

IC 416: Separate cooling or liquid cooled motors

Suitable for constant torque 0 - n_n , constant power n_n - n_{max}

Network voltage 690 V, at motor terminals 638 V

Output kW	Type designation ¹⁾	Product code ¹⁾	Current I_N A	Efficiency Full load ²⁾ %	Torque T_N Nm	Power factor cos φ	Torque $\frac{T_{max}}{T_N}$ ⁴⁾	Moment of inertia $J=1/4GD^2$ kgm ²	Maximum speed, n_{max} r/min	Weight approx. kg
$n_n = 220$ r/min										
30	M3_J 280SMB	3G_J286220-_D_183705	33	87.9	1303	0.92	1.0	2.2	220	660
40	M3_J 315SMC	3G_J316230-_D_183705	43	90.5	1743	0.93	1.1	3.9	220	890
63	M3_J 315MLA	3G_J316410-_D_183705	67	91.3	2734	0.94	1.1	5.8	220	1125
80	M3_J 315LKB	3G_J316820-_D_183705	82	91.9	3472	0.95	1.1	7.8	220	1430
100	M3_J 315LKC	3G_J316830-_D_183705	105	92.7	4350	0.93	1.1	9.8	220	1605
109	M3_J 355SMB	3G_J356220-_D_183705	111	92.5	4769	0.96	1.2	17.1	220	1780
149	M3_J 355MLB	3G_J356420-_D_183705	152	92.9	6501	0.96	1.2	22.4	220	2210
174	M3_J 355LKB	3G_J356820-_D_183705	175	93.4	7591	0.96	1.2	28.5	220	2690
219	M3_J 400LC	3G_J406530-_D_183705	217	94.1	9546	0.97	1.1	41.1	220	3280
305	AMZ 0500LE10_AM		310	95.7	13240	0.93	1.3	68	264	5240
413	AMZ 0500LJ10_AM		412	96.1	17928	0.94	1.2	90	264	6020
532	AMZ 0500LN10_AM		529	96.3	23094	0.94	1.2	113	264	6800
673	AMZ 0500LR10_AM		678	96.5	29214	0.93	1.3	135	264	7580
834	AMZ 0560LQ10_AM		830	96.8	36203	0.94	1.4	224	264	10490
1003	AMZ 0560LS10_AM		1007	96.9	43539	0.93	1.4	265	264	11480
1157	AMZ 0560LU10_AM		1142	97	50224	0.94	1.3	306	264	12470
$n_n = 300$ r/min										
41	M3_J 280SMB	3G_J286220-_D_183706	45	90.7	1303	0.91	1.0	2.2	300	660
63	M3_J 315SMC	3G_J316230-_D_183706	67	91.8	2006	0.92	1.0	3.9	300	890
90	M3_J 315MLA	3G_J316410-_D_183706	93	92.8	2864	0.94	1.0	5.8	300	1125
110	M3_J 315LKB	3G_J316820-_D_183706	114	93.7	3500	0.93	1.1	7.8	300	1430
150	M3_J 315LKC	3G_J316830-_D_183706	157	93.7	4786	0.92	1.1	9.8	300	1605
149	M3_J 355SMB	3G_J356220-_D_183706	149	94.0	4769	0.96	1.2	17.1	300	1780
199	M3_J 355MLB	3G_J356420-_D_183706	199	94.4	6355	0.96	1.2	22.4	300	2210
224	M3_J 355LKB	3G_J356820-_D_183706	227	94.9	7153	0.94	1.3	28.5	300	2690
299	M3_J 400LC	3G_J406530-_D_183706	293	95.3	9543	0.97	1.1	41.1	300	3280
414	AMZ 0500LE10_AM		416	96.5	13179	0.93	1.2	68	360	5240
574	AMZ 0500LJ10_AM		573	96.8	18272	0.93	1.3	90	360	6020
746	AMZ 0500LN10_AM		746	97.0	23748	0.93	1.3	113	360	6800
918	AMZ 0500LR10_AM		923	97.2	29223	0.92	1.3	135	360	7580
1138	AMZ 0560LQ10_AM		1131	97.4	36226	0.93	1.4	224	360	10490
1322	AMZ 0560LS10_AM		1289	97.4	42084	0.95	1.4	265	360	11480
1542	AMZ 0560LU10_AM		1503	97.5	49087	0.95	1.4	306	360	12470
$n_n = 380$ r/min										
51	M3_J 280SMB	3G_J286220-_D_183705	55	91.9	1283	0.91	1.0	2.2	380	660
66	M3_J 315SMC	3G_J316230-_D_183705	70	93.3	1653	0.91	1.2	3.9	380	890
103	M3_J 315MLA	3G_J316410-_D_183705	107	93.9	2599	0.93	1.1	5.8	380	1125
131	M3_J 315LKB	3G_J316820-_D_183705	132	94.3	3289	0.95	1.1	7.8	380	1430
160	M3_J 315LKC	3G_J316830-_D_183705	165	94.8	4023	0.93	1.2	9.8	380	1605
177	M3_J 355SMB	3G_J356220-_D_183705	176	94.7	4451	0.96	1.3	17.1	380	1780
241	M3_J 355MLB	3G_J356420-_D_183705	240	94.9	6065	0.96	1.3	22.4	380	2210
278	M3_J 355LKB	3G_J356820-_D_183705	274	95.2	6985	0.96	1.3	28.5	380	2690
353	M3_J 400LC	3G_J406530-_D_183705	342	95.8	8887	0.98	1.2	41.1	380	3280
527	AMZ 0500LE10_AM		530	97.0	13244	0.92	1.3	68	456	5240
739	AMZ 0500LJ10_AM		742	97.2	18572	0.92	1.3	90	456	6020
931	AMZ 0500LN10_AM		924	97.4	23398	0.93	1.3	113	456	6800
1149	AMZ 0560LL10_AM		1135	97.6	28876	0.93	1.4	183	456	9500
1538	AMZ 0560LR10_AM		1499	97.7	38652	0.94	1.4	245	456	10990
1845	AMZ 0560LT10_AM		1809	97.8	46368	0.94	1.4	286	456	11980

¹⁾ See ordering information - section for details on motor type and product code, variant code 183 used only with air cooled, IC 416 motors
²⁾ Separate cooling fan power not considered in efficiency value

³⁾ Output values and more base speeds for IEC 500 and 560 sizes on request
⁴⁾ $\frac{T_{max}}{T_N}$ value represents maximum short time overloadability with inverter supply. This does not represent the pull-out torque value according to IEC.

Permanent magnet synchronous motors

690 V Technical data

IC 416: Separate cooling or liquid cooled motors

Suitable for constant torque 0 - n_n , constant power n_n - n_{max}

Network voltage 690 V, at motor terminals 638 V

Output kW	Type designation ¹⁾	Product code ¹⁾	Current I_N A	Efficiency Full load ²⁾ %	Torque T_N Nm	Power factor $\cos \varphi$	Torque $\frac{T_{max}}{T_N}$ ⁴⁾	Moment of inertia $J=1/4GD^2$ kgm ²	Maximum speed, n_{max} r/min	Weight approx. kg
$n_n = 430$ r/min										
55	M3_J 280SMB	3G_J286220-_D_183707	58	92.9	1222	0.92	1.0	2.2	430	660
80	M3_J 315SMC	3G_J316230-_D_183707	82	93.9	1776	0.94	1.1	3.9	430	890
124	M3_J 315MLA	3G_J316410-_D_183707	129	94.5	2774	0.93	1.1	5.8	430	1125
149	M3_J 315LKB	3G_J316820-_D_183707	152	95.0	3329	0.94	1.2	7.8	430	1430
199	M3_J 315LKC	3G_J316830-_D_183707	203	95.1	4440	0.94	1.1	9.8	430	1605
199	M3_J 355SMB	3G_J356220-_D_183707	193	95.0	4440	0.98	1.2	17.1	430	1780
278	M3_J 355MLB	3G_J356420-_D_183707	281	95.6	6205	0.94	1.3	22.4	430	2210
333	M3_J 355LKB	3G_J356820-_D_183707	328	95.8	7433	0.96	1.3	28.5	430	2690
421	M3_J 400LC	3G_J406530-_D_183707	432	96.3	9394	0.92	1.3	41.1	430	3280
572	AMZ 0500LE10 _AM		564	97.2	12704	0.94	1.3	68	516	5240
826	AMZ 0500LJ10 _AM		823	97.4	18345	0.93	1.3	90	516	6020
1061	AMZ 0500LN10 _AM		1055	97.5	23564	0.93	1.3	113	516	6800
1298	AMZ 0560LL10 _AM		1286	97.7	28828	0.93	1.4	183	516	9500
1781	AMZ 0560LR10 _AM		1796	97.8	39555	0.93	1.4	245	516	10990
2267	AMZ 0560LU10 _AM		2244	97.9	50348	0.93	1.4	306	516	12470
$n_n = 518$ r/min										
68	M3_J 280SMB	3G_J286220-_D_183706	72	93.5	1245	0.91	1.0	2.2	518	660
103	M3_J 315SMC	3G_J316230-_D_183706	107	94.2	1899	0.92	1.1	3.9	518	890
145	M3_J 315MLA	3G_J316410-_D_183706	147	94.8	2674	0.94	1.1	5.8	518	1125
170	M3_J 315LKB	3G_J316820-_D_183706	174	95.3	3139	0.93	1.3	7.8	518	1430
235	M3_J 315LKC	3G_J316830-_D_183706	241	95.4	4344	0.93	1.2	9.8	518	1605
233	M3_J 355SMB	3G_J356220-_D_183706	228	95.5	4296	0.97	1.3	17.1	518	1780
307	M3_J 355MLB	3G_J356420-_D_183706	301	95.8	5656	0.96	1.3	22.4	518	2210
326	M3_J 355LKB	3G_J356820-_D_183706	328	95.9	6011	0.94	1.5	28.5	518	2690
462	M3_J 400LC	3G_J406530-_D_183706	445	96.5	8532	0.97	1.3	41.1	518	3280
714	AMZ 0500LE10 _AM		733	97.4	13164	0.92	1.3	68	622	5240
1423	AMZ 0500LQ10 _AM		1458	97.8	26235	0.92	1.3	124	622	7190
1527	AMZ 0560LL10 _AM		1491	97.9	28152	0.94	1.4	183	622	9500
2285	AMZ 0560LS10 _AM		2228	98.0	42127	0.94	1.4	265	622	11480
$n_n = 600$ r/min										
80	M3_J 280SMB	3G_J286220-_D_183708	86	94.1	1274	0.90	1.0	2.2	600	660
110	M3_J 315SMC	3G_J316230-_D_183708	113	95.0	1750	0.93	1.1	3.9	600	890
159	M3_J 315MLA	3G_J316410-_D_183708	159	95.4	2546	0.95	1.1	5.8	600	1125
199	M3_J 315LKB	3G_J316820-_D_183708	205	95.8	3179	0.92	1.3	7.8	600	1430
249	M3_J 315LKC	3G_J316830-_D_183708	247	95.9	3976	0.95	1.2	9.8	600	1605
249	M3_J 355SMB	3G_J356220-_D_183708	245	96.0	3973	0.96	1.4	17.1	600	1780
373	M3_J 355MLB	3G_J356420-_D_183708	368	96.2	5963	0.95	1.3	22.4	600	2210
423	M3_J 355LKB	3G_J356820-_D_183708	402	96.2	6763	0.99	1.3	28.5	600	2690
557	M3_J 400LC	3G_J406530-_D_183708	539	96.9	8904	0.97	1.2	41.1	600	3280
819	AMZ 0500LE10 _AM		816	97.5	13036	0.93	1.3	68	720	5240
1468	AMZ 0500LN10 _AM		1457	97.8	23366	0.93	1.3	113	720	6800
1800	AMZ 0500LR10 _AM		1808	97.9	28650	0.92	1.3	135	720	7580
2235	AMZ 0560LQ10 _AM		2219	98.1	35574	0.93	1.4	224	720	10490
2594	AMZ 0560LU10 _AM		2467	98.2	41288	0.96	1.6	306	720	12470

¹⁾ See ordering information - section for details on motor type and product code, variant code 183 used only with air cooled, IC 416 motors

²⁾ Separate cooling fan power not considered in efficiency value

³⁾ Output values and more base speeds for IEC 500 and 560 sizes on request

⁴⁾ T_{max}/T_N value represents maximum short time overloadability with inverter supply. This does not represent the pull-out torque value according to IEC.

Permanent magnet synchronous motors

690 V Technical data

IC 416: Separate cooling or liquid cooled motors

Suitable for constant torque 0 - n_n , constant power n_n - n_{max}

Network voltage 690 V, at motor terminals 638 V

Output kW	Type designation ¹⁾	Product code ¹⁾	Current I_N A	Efficiency Full load ²⁾ %	Torque T_N Nm	Power factor $\cos \varphi$	Torque $\frac{T_{max}}{T_N}$ ⁴⁾	Moment of inertia $J=1/4GD^2$ kgm ²	Maximum speed, n_{max} r/min	Weight approx. kg
$n_n = 742$ r/min										
86	M3_J 280SMB	3G_J286220-_D_183707	90	94.6	1106	0.92	1.1	2.2	742	660
123	M3_J 315SMC	3G_J316230-_D_183707	123	95.3	1580	0.95	1.2	3.9	742	890
188	M3_J 315MLA	3G_J316410-_D_183707	191	95.7	2417	0.93	1.3	5.8	742	1125
215	M3_J 315LKB	3G_J316820-_D_183707	216	95.9	2772	0.94	1.4	7.8	742	1430
290	M3_J 315LKC	3G_J316830-_D_183707	289	96.0	3730	0.95	1.3	9.8	742	1605
291	M3_J 355SMB	3G_J356220-_D_183707	277	96.0	3748	0.99	1.4	17.1	742	1780
384	M3_J 355MLB	3G_J356420-_D_183707	387	96.2	4940	0.93	1.6	22.4	742	2210
452	M3_J 355LKB	3G_J356820-_D_183707	439	96.3	5818	0.97	1.7	28.5	742	2690
569	M3_J 400LC	3G_J406530-_D_183707	584	96.8	7321	0.91	1.7	41.1	742	3280
1007	AMZ 0500LE10 _AM		1030	97.7	12961	0.92	1.3	68	890	5240
1403	AMZ 0500LJ10 _AM		1432	97.8	18057	0.92	1.3	90	890	6020
1801	AMZ 0500LN10 _AM		1790	97.9	23180	0.92	1.3	113	890	6800
2185	AMZ 0560LL10 _AM		2192	98.1	28122	0.93	1.4	183	890	9500
2592	AMZ 0560LR10 _AM		2495	98.1	33361	0.95	1.6	245	890	10990

¹⁾ See ordering information - section for details on motor type and product code, variant code 183 used only with air cooled, IC416 motors
²⁾ Separate cooling fan power not considered in efficiency value

³⁾ Output values and more base speeds for IEC 500 and 560 sizes on request
⁴⁾ T_{max}/T_N value represents maximum short time overloadability with inverter supply. This does not represent the pull-out torque value according to IEC.

Permanent magnet synchronous motors

400 V Technical data

IC 411: Self ventilated motors

Loadability according to Figure 1 on page 6

Network voltage 400 V, at motor terminals 370 V

Output kW	Type designation ¹⁾	Product code ¹⁾	Current I _N A	Efficiency Full load %	Torque T _N Nm	Power factor cos φ	Torque $\frac{T_{max}}{T_N^{3)}$	Moment of inertia J=1/4GD ² kgm ²	Maximum speed, n _{max} r/min	Weight approx. kg
n_n = 127 r/min										
11	M3BJ 280SMB	3GBJ286220-_DG705	21	86.5	819	0.93	1.4	2.2	152	650
16	M3BJ 315SMC	3GBJ316230-_DG705	31	88.1	1228	0.92	1.5	3.9	152	880
24	M3BJ 315MLA	3GBJ316410-_DG705	45	90.0	1833	0.94	1.5	5.8	152	1115
30	M3BJ 315LKB	3GBJ316820-_DG705	53	90.9	2242	0.97	1.5	7.8	152	1415
41	M3BJ 315LKC	3GBJ316830-_DG705	75	91.2	3052	0.93	1.5	9.8	152	1590
40	M3BJ 355SMB	3GBJ356220-_DG705	72	91.4	3038	0.96	1.8	17.1	152	1765
54	M3BJ 355MLB	3GBJ356420-_DG705	96	91.8	4047	0.95	1.8	22.4	152	2190
67	M3BJ 355LKB	3GBJ356820-_DG705	116	92.5	5067	0.98	1.7	28.5	152	2670
81	M3BJ 400LC	3GBJ406530-_DG705	137	93.5	6103	0.99	1.6	41.1	152	3260
2) AMZ 0500L_10 RAM										
2) AMZ 0560L_10 RAM										
n_n = 173 r/min										
16	M3BJ 280SMB	3GBJ286220-_DG706	31	89.1	899	0.93	1.3	2.2	208	650
24	M3BJ 315SMC	3GBJ316230-_DG706	45	90.7	1343	0.93	1.4	3.9	208	880
34	M3BJ 315MLA	3GBJ316410-_DG706	61	91.9	1880	0.95	1.5	5.8	208	1115
43	M3BJ 315LKB	3GBJ316820-_DG706	79	92.7	2385	0.93	1.6	7.8	208	1415
54	M3BJ 315LKC	3GBJ316830-_DG706	99	92.8	2980	0.91	1.6	9.8	208	1590
54	M3BJ 355SMB	3GBJ356220-_DG706	93	93.1	2967	0.97	1.8	17.1	208	1765
81	M3BJ 355MLB	3GBJ356420-_DG706	140	93.5	4447	0.96	1.6	22.4	208	2190
99	M3BJ 355LKB	3GBJ356820-_DG706	173	93.9	5481	0.95	1.7	28.5	208	2670
119	M3BJ 400LC	3GBJ406530-_DG706	200	94.6	6557	0.98	1.6	41.1	208	3260
2) AMZ 0500L_10 RAM										
2) AMZ 0560L_10 RAM										
n_n = 220 r/min										
20	M3BJ 280SMB	3GBJ286220-_DG705	39	90.1	869	0.90	1.3	2.2	264	650
30	M3BJ 315SMC	3GBJ316230-_DG705	57	91.2	1307	0.90	1.4	3.9	264	880
45	M3BJ 315MLA	3GBJ316410-_DG705	83	92.6	1953	0.92	1.4	5.8	264	1115
55	M3BJ 315LKB	3GBJ316820-_DG705	97	93.2	2387	0.95	1.4	7.8	264	1415
75	M3BJ 315LKC	3GBJ316830-_DG705	137	93.5	3254	0.91	1.4	9.8	264	1590
75	M3BJ 355SMB	3GBJ356220-_DG705	132	93.4	3253	0.95	1.6	17.1	264	1765
100	M3BJ 355MLB	3GBJ356420-_DG705	177	93.9	4335	0.94	1.7	22.4	264	2190
125	M3BJ 355LKB	3GBJ356820-_DG705	212	94.3	5422	0.98	1.6	28.5	264	2670
150	M3BJ 400LC	3GBJ406530-_DG705	251	95.1	6507	0.98	1.5	41.1	264	3260
2) AMZ 0500L_10 RAM										
2) AMZ 0560L_10 RAM										
n_n = 248 r/min										
25	M3BJ 280SMB	3GBJ286220-_DG707	45	91.4	940	0.93	1.3	2.2	298	650
34	M3BJ 315SMC	3GBJ316230-_DG707	60	92.7	1312	0.95	1.4	3.9	298	880
54	M3BJ 315MLA	3GBJ316410-_DG707	97	93.3	2079	0.93	1.4	5.8	298	1115
68	M3BJ 315LKB	3GBJ316820-_DG707	119	94.0	2599	0.94	1.4	7.8	298	1415
87	M3BJ 315LKC	3GBJ316830-_DG707	152	94.2	3327	0.95	1.4	9.8	298	1590
81	M3BJ 355SMB	3GBJ356220-_DG707	135	94.3	3111	0.99	1.6	17.1	298	1765
118	M3BJ 355MLB	3GBJ356420-_DG707	211	94.7	4535	0.92	1.7	22.4	298	2190
150	M3BJ 355LKB	3GBJ356820-_DG707	256	94.9	5787	0.97	1.6	28.5	298	2670
181	M3BJ 400LC	3GBJ406530-_DG707	330	95.6	6941	0.89	1.7	41.1	298	3260
2) AMZ 0500L_10 RAM										
2) AMZ 0560L_10 RAM										

¹⁾ See ordering information - section for details on motor type and product code.

²⁾ Performance values for IEC frame sizes 500 and 560 on request

³⁾ T_{max}/T_n value represents maximum short time overloadability with inverter supply. This does not represent the pull-out torque value according to IEC.

Permanent magnet synchronous motors

400 V Technical data

IC 411: Self ventilated motors

Loadability according to Figure 1 on page 6

Network voltage 400 V, at motor terminals 370 V

Output kW	Type designation ¹⁾	Product code ¹⁾	Current I_N A	Efficiency Full load %	Torque T_N Nm	Power factor $\cos \varphi$	Torque $\frac{T_{max}}{T_N}$ ³⁾	Moment of inertia $J=1/4GD^2$ kgm ²	Maximum speed, n_{max} r/min	Weight approx. kg
$n_n = 300$ r/min										
30	M3BJ 280SMB	3GBJ286220-_DG706	57	91.7	955	0.90	1.3	2.2	360	650
45	M3BJ 315SMC	3GBJ316230-_DG706	83	93.0	1432	0.91	1.3	3.9	360	880
63	M3BJ 315MLA	3GBJ316410-_DG706	112	93.9	2004	0.94	1.4	5.8	360	1115
80	M3BJ 315LKB	3GBJ316820-_DG706	145	94.3	2546	0.91	1.5	7.8	360	1415
100	M3BJ 315LKC	3GBJ316830-_DG706	183	94.5	3183	0.90	1.5	9.8	360	1590
100	M3BJ 355SMB	3GBJ356220-_DG706	172	94.6	3180	0.96	1.7	17.1	360	1765
150	M3BJ 355MLB	3GBJ356420-_DG706	258	94.9	4767	0.95	1.5	22.4	360	2190
185	M3BJ 355LKB	3GBJ356820-_DG706	321	95.2	5886	0.95	1.6	28.5	360	2670
220	M3BJ 400LC	3GBJ406530-_DG706	368	95.9	6996	0.97	1.5	41.1	360	3260
2)	AMZ 0500L_10 RAM									
2)	AMZ 0560L_10 RAM									
$n_n = 346$ r/min										
36	M3BJ 280SMB	3GBJ286220-_DG708	68	92.9	1003	0.90	1.3	2.2	415	650
54	M3BJ 315SMC	3GBJ316230-_DG708	96	93.9	1490	0.94	1.3	3.9	415	880
71	M3BJ 315MLA	3GBJ316410-_DG708	122	94.6	1969	0.96	1.4	5.8	415	1115
86	M3BJ 315LKB	3GBJ316820-_DG708	157	94.9	2379	0.91	1.6	7.8	415	1415
108	M3BJ 315LKC	3GBJ316830-_DG708	184	95.2	2980	0.96	1.5	9.8	415	1590
107	M3BJ 355SMB	3GBJ356220-_DG708	185	95.3	2960	0.95	1.9	17.1	415	1765
180	M3BJ 355MLB	3GBJ356420-_DG708	307	95.5	4960	0.96	1.5	22.4	415	2190
191	M3BJ 355LKB	3GBJ356820-_DG708	313	95.6	5274	1.00	1.6	28.5	415	2670
254	M3BJ 400LC	3GBJ406530-_DG708	422	96.4	6996	0.97	1.5	41.1	415	3260
2)	AMZ 0500L_10 RAM									
2)	AMZ 0560L_10 RAM									
$n_n = 430$ r/min										
45	M3BJ 280SMB	3GBJ286220-_DG707	82	93.4	1000	0.91	1.2	2.2	516	650
63	M3BJ 315SMC	3GBJ316230-_DG707	111	94.3	1399	0.94	1.3	3.9	516	880
100	M3BJ 315MLA	3GBJ316410-_DG707	178	94.9	2219	0.92	1.3	5.8	516	1115
125	M3BJ 315LKB	3GBJ316820-_DG707	220	95.2	2774	0.93	1.4	7.8	516	1415
160	M3BJ 315LKC	3GBJ316830-_DG707	280	95.4	3552	0.93	1.3	9.8	516	1590
150	M3BJ 355SMB	3GBJ356220-_DG707	249	95.4	3331	0.99	1.5	17.1	516	1765
220	M3BJ 355MLB	3GBJ356420-_DG707	392	95.6	4879	0.92	1.6	22.4	516	2190
280	M3BJ 355LKB	3GBJ356820-_DG707	475	95.9	6215	0.96	1.5	28.5	516	2670
333	M3BJ 400LC	3GBJ406530-_DG707	607	96.4	7387	0.89	1.6	41.1	516	3260
2)	AMZ 0500L_10 RAM									
2)	AMZ 0560L_10 RAM									
$n_n = 600$ r/min										
67	M3BJ 280SMB	3GBJ286220-_DG708	125	94.4	1068	0.89	1.2	2.2	720	650
100	M3BJ 315SMC	3GBJ316230-_DG708	177	95.1	1591	0.93	1.2	3.9	720	880
132	M3BJ 315MLA	3GBJ316410-_DG708	226	95.6	2100	0.95	1.3	5.8	720	1115
160	M3BJ 315LKB	3GBJ316820-_DG708	290	95.7	2545	0.90	1.5	7.8	720	1415
200	M3BJ 315LKC	3GBJ316830-_DG708	341	95.9	3182	0.95	1.4	9.8	720	1590
200	M3BJ 355SMB	3GBJ356220-_DG708	344	95.9	3181	0.95	1.7	17.1	720	1765
335	M3BJ 355MLB	3GBJ356420-_DG708	571	96.2	5327	0.95	1.4	22.4	720	2190
355	M3BJ 355LKB	3GBJ356820-_DG708	578	96.3	5643	0.99	1.5	28.5	720	2670
470	M3BJ 400LC	3GBJ406530-_DG708	782	96.9	7472	0.97	1.4	41.1	720	3260
2)	AMZ 0500L_10 RAM									
2)	AMZ 0560L_10 RAM									

¹⁾ See ordering information - section for details on motor type and product code

²⁾ Performance values for IEC frame sizes 500 and 560 on request

³⁾ T_{max}/T_n value represents maximum short time overloadability with inverter supply. This does not represent the pull-out torque value according to IEC.

Permanent magnet synchronous motors

460 V Technical data

IC 411: Self ventilated motors

Loadability according to Figure 1 on page 6

Network voltage 460 V, at motor terminals 426 V

Output kW	Type designation ¹⁾	Product code ¹⁾	Current I_N A	Efficiency Full load %	Torque T_N Nm	Power factor $\cos \varphi$	Torque $\frac{T_{max}}{T_N^{3)}$	Moment of inertia $J=1/4GD^2$ kgm ²	Maximum speed, n_{max} r/min	Weight approx. kg
$n_n = 146$ r/min										
13	M3BJ 280SMB	3GBJ286220-_DG705	22	87.6	830	0.92	1.4	2.2	175	650
19	M3BJ 315SMC	3GBJ316230-_DG705	32	89.3	1246	0.91	1.5	3.9	175	880
29	M3BJ 315MLA	3GBJ316410-_DG705	46	90.8	1861	0.93	1.5	5.8	175	1115
35	M3BJ 315LKB	3GBJ316820-_DG705	54	91.6	2275	0.96	1.5	7.8	175	1415
47	M3BJ 315LKC	3GBJ316830-_DG705	76	91.9	3098	0.93	1.5	9.8	175	1590
47	M3BJ 355SMB	3GBJ356220-_DG705	73	92.0	3086	0.96	1.7	17.1	175	1765
63	M3BJ 355MLB	3GBJ356420-_DG705	97	92.5	4112	0.95	1.7	22.4	175	2190
79	M3BJ 355LKB	3GBJ356820-_DG705	117	93.0	5148	0.98	1.7	28.5	175	2670
95	M3BJ 400LC	3GBJ406530-_DG705	139	94.0	6197	0.99	1.6	41.1	175	3260
2)	AMZ 0500L_10 RAM									
2)	AMZ 0560L_10 RAM									
$n_n = 199$ r/min										
19	M3BJ 280SMB	3GBJ286220-_DG706	31	89.6	912	0.92	1.3	2.2	239	650
28	M3BJ 315SMC	3GBJ316230-_DG706	46	91.0	1364	0.93	1.4	3.9	239	880
40	M3BJ 315MLA	3GBJ316410-_DG706	62	92.3	1908	0.95	1.4	5.8	239	1115
51	M3BJ 315LKB	3GBJ316820-_DG706	80	93.2	2422	0.92	1.5	7.8	239	1415
63	M3BJ 315LKC	3GBJ316830-_DG706	101	93.3	3026	0.91	1.6	9.8	239	1590
63	M3BJ 355SMB	3GBJ356220-_DG706	95	93.6	3016	0.96	1.8	17.1	239	1765
94	M3BJ 355MLB	3GBJ356420-_DG706	142	93.9	4521	0.96	1.6	22.4	239	2190
116	M3BJ 355LKB	3GBJ356820-_DG706	176	94.2	5573	0.95	1.7	28.5	239	2670
139	M3BJ 400LC	3GBJ406530-_DG706	203	95.0	6660	0.98	1.5	41.1	239	3260
2)	AMZ 0500L_10 RAM									
2)	AMZ 0560L_10 RAM									
$n_n = 253$ r/min										
23	M3BJ 280SMB	3GBJ286220-_DG705	38	90.8	857	0.89	1.3	2.2	304	650
34	M3BJ 315SMC	3GBJ316230-_DG705	57	92.2	1286	0.89	1.5	3.9	304	880
51	M3BJ 315MLA	3GBJ316410-_DG705	81	93.2	1920	0.91	1.4	5.8	304	1115
62	M3BJ 315LKB	3GBJ316820-_DG705	94	93.6	2338	0.95	1.5	7.8	304	1415
84	M3BJ 315LKC	3GBJ316830-_DG705	134	93.9	3182	0.91	1.5	9.8	304	1590
84	M3BJ 355SMB	3GBJ356220-_DG705	128	94.0	3171	0.95	1.7	17.1	304	1765
112	M3BJ 355MLB	3GBJ356420-_DG705	172	94.2	4225	0.94	1.7	22.4	304	2190
140	M3BJ 355LKB	3GBJ356820-_DG705	206	94.6	5272	0.97	1.7	28.5	304	2670
168	M3BJ 400LC	3GBJ406530-_DG705	245	95.4	6352	0.98	1.6	41.1	304	3260
2)	AMZ 0500L_10 RAM									
2)	AMZ 0560L_10 RAM									
$n_n = 286$ r/min										
29	M3BJ 280SMB	3GBJ286220-_DG707	46	91.6	954	0.93	1.3	2.2	343	650
40	M3BJ 315SMC	3GBJ316230-_DG707	61	93.0	1332	0.95	1.4	3.9	343	880
63	M3BJ 315MLA	3GBJ316410-_DG707	98	93.8	2111	0.93	1.4	5.8	343	1115
79	M3BJ 315LKB	3GBJ316820-_DG707	121	94.3	2640	0.94	1.4	7.8	343	1415
101	M3BJ 315LKC	3GBJ316830-_DG707	154	94.6	3379	0.94	1.4	9.8	343	1590
95	M3BJ 355SMB	3GBJ356220-_DG707	137	94.6	3162	0.99	1.6	17.1	343	1765
138	M3BJ 355MLB	3GBJ356420-_DG707	214	95.0	4615	0.92	1.7	22.4	343	2190
176	M3BJ 355LKB	3GBJ356820-_DG707	260	95.2	5885	0.96	1.6	28.5	343	2670
211	M3BJ 400LC	3GBJ406530-_DG707	335	95.8	7057	0.89	1.6	41.1	343	3260
2)	AMZ 0500L_10 RAM									
2)	AMZ 0560L_10 RAM									

¹⁾ See ordering information - section for details on motor type and product code

²⁾ Performance values for IEC frame sizes 500 and 560 on request

³⁾ T_{max}/T_n value represents maximum short time overloadability with inverter supply. This does not represent the pull-out torque value according to IEC.

Permanent magnet synchronous motors

460 V Technical data

IC 411: Self ventilated motors

Loadability according to Figure 1 on page 6

Network voltage 460 V, at motor terminals 426 V

Output kW	Type designation ¹⁾	Product code ¹⁾	Current I _N A	Efficiency Full load %	Torque T _N Nm	Power factor cos φ	Torque $\frac{T_{max}}{T_N}$ ³⁾	Moment of inertia J=1/4GD ² kgm ²	Maximum speed, n _{max} r/min	Weight approx. kg
n_n = 345 r/min										
34	M3BJ 280SMB	3GBJ286220-_DG706	56	92.4	940	0.90	1.3	2.2	414	650
51	M3BJ 315SMC	3GBJ316230-_DG706	81	93.6	1405	0.91	1.4	3.9	414	880
71	M3BJ 315MLA	3GBJ316410-_DG706	109	94.3	1956	0.93	1.4	5.8	414	1115
89	M3BJ 315LKB	3GBJ316820-_DG706	140	94.6	2462	0.91	1.5	7.8	414	1415
111	M3BJ 315LKC	3GBJ316830-_DG706	177	94.8	3064	0.90	1.5	9.8	414	1590
111	M3BJ 355SMB	3GBJ356220-_DG706	166	94.9	3067	0.95	1.7	17.1	414	1765
168	M3BJ 355MLB	3GBJ356420-_DG706	251	95.2	4636	0.95	1.6	22.4	414	2190
204	M3BJ 355LKB	3GBJ356820-_DG706	308	95.4	5642	0.94	1.7	28.5	414	2670
246	M3BJ 400LC	3GBJ406530-_DG706	357	96.1	6805	0.97	1.5	41.1	414	3260
3) AMZ 0500L_10 RAM										
3) AMZ 0560L_10 RAM										
n_n = 398 r/min										
43	M3BJ 280SMB	3GBJ286220-_DG708	69	93.4	1018	0.90	1.3	2.2	478	650
63	M3BJ 315SMC	3GBJ316230-_DG708	97	94.3	1514	0.94	1.3	3.9	478	880
83	M3BJ 315MLA	3GBJ316410-_DG708	124	94.9	2000	0.96	1.4	5.8	478	1115
101	M3BJ 315LKB	3GBJ316820-_DG708	159	95.3	2418	0.90	1.6	7.8	478	1415
126	M3BJ 315LKC	3GBJ316830-_DG708	187	95.4	3028	0.96	1.5	9.8	478	1590
126	M3BJ 355SMB	3GBJ356220-_DG708	188	95.4	3011	0.95	1.8	17.1	478	1765
211	M3BJ 355MLB	3GBJ356420-_DG708	312	95.7	5046	0.96	1.5	22.4	478	2190
224	M3BJ 355LKB	3GBJ356820-_DG708	318	95.8	5361	1.00	1.6	28.5	478	2670
297	M3BJ 400LC	3GBJ406530-_DG708	429	96.5	7109	0.97	1.5	41.1	478	3260
2) AMZ 0500L_10 RAM										
2) AMZ 0560L_10 RAM										
n_n = 495 r/min										
51	M3BJ 280SMB	3GBJ286220-_DG707	80	93.7	978	0.91	1.2	2.2	594	650
70	M3BJ 315SMC	3GBJ316230-_DG707	107	94.6	1360	0.94	1.4	3.9	594	880
111	M3BJ 315MLA	3GBJ316410-_DG707	173	95.1	2152	0.92	1.3	5.8	594	1115
139	M3BJ 315LKB	3GBJ316820-_DG707	212	95.4	2677	0.93	1.4	7.8	594	1415
177	M3BJ 315LKC	3GBJ316830-_DG707	268	95.6	3411	0.93	1.4	9.8	594	1590
165	M3BJ 355SMB	3GBJ356220-_DG707	237	95.6	3180	0.99	1.6	17.1	594	1765
240	M3BJ 355MLB	3GBJ356420-_DG707	373	95.8	4628	0.91	1.7	22.4	594	2190
305	M3BJ 355LKB	3GBJ356820-_DG707	450	96.0	5896	0.96	1.6	28.5	594	2670
359	M3BJ 400LC	3GBJ406530-_DG707	572	96.5	6930	0.88	1.7	41.1	594	3260
2) AMZ 0500L_10 RAM										
2) AMZ 0560L_10 RAM										
n_n = 690 r/min										
74	M3BJ 280SMB	3GBJ286220-_DG708	120	94.5	1030	0.89	1.2	2.2	828	650
111	M3BJ 315SMC	3GBJ316230-_DG708	170	95.3	1533	0.93	1.3	3.9	828	880
145	M3BJ 315MLA	3GBJ316410-_DG708	215	95.8	2009	0.96	1.4	5.8	828	1115
171	M3BJ 315LKB	3GBJ316820-_DG708	271	95.8	2369	0.90	1.6	7.8	828	1415
215	M3BJ 315LKC	3GBJ316830-_DG708	319	95.9	2980	0.96	1.5	9.8	828	1590
211	M3BJ 355SMB	3GBJ356220-_DG708	317	95.9	2917	0.94	1.9	17.1	828	1765
365	M3BJ 355MLB	3GBJ356420-_DG708	540	96.3	5048	0.95	1.5	22.4	828	2190
382	M3BJ 355LKB	3GBJ356820-_DG708	540	96.3	5286	1.00	1.6	28.5	828	2670
513	M3BJ 400LC	3GBJ406530-_DG708	740	97.0	7094	0.97	1.5	41.1	828	3260
2) AMZ 0500L_10 RAM										
2) AMZ 0560L_10 RAM										

¹⁾ See ordering information - section for details on motor type and product code

²⁾ Performance values for IEC frame sizes 500 and 560 on request

³⁾ T_{max}/T_n value represents maximum short time overloadability with inverter supply. This does not represent the pull-out torque value according to IEC.

Permanent magnet synchronous motors

500 V Technical data

IC 411: Self ventilated motors

Loadability according to Figure 1 on page 6

Network voltage 500 V, at motor terminals 463 V

Output kW	Type designation ¹⁾	Product code ¹⁾	Current I _N A	Efficiency Full load %	Torque T _N Nm	Power factor cos φ	Torque $\frac{T_{max}}{T_N^{3)}$	Moment of inertia J=1/4GD ² kgm ²	Maximum speed, n _{max} r/min	Weight approx. kg
n_n = 159 r/min										
14	M3BJ 280SMB	3GBJ286220-_DG705	22	88.0	838	0.91	1.4	2.2	191	650
21	M3BJ 315SMC	3GBJ316230-_DG705	32	89.7	1258	0.91	1.5	3.9	191	880
31	M3BJ 315MLA	3GBJ316410-_DG705	46	91.0	1879	0.93	1.5	5.8	191	1115
38	M3BJ 315LKB	3GBJ316820-_DG705	54	92.0	2298	0.96	1.5	7.8	191	1415
52	M3BJ 315LKC	3GBJ316830-_DG705	76	92.2	3130	0.92	1.5	9.8	191	1590
52	M3BJ 355SMB	3GBJ356220-_DG705	73	92.5	3120	0.96	1.7	17.1	191	1765
69	M3BJ 355MLB	3GBJ356420-_DG705	98	92.8	4158	0.95	1.7	22.4	191	2190
87	M3BJ 355LKB	3GBJ356820-_DG705	118	93.3	5204	0.98	1.7	28.5	191	2670
104	M3BJ 400LC	3GBJ406530-_DG705	140	94.2	6261	0.98	1.6	41.1	191	3260
2)	AMZ 0500L_10 RAM									
2)	AMZ 0560L_10 RAM									
n_n = 217 r/min										
21	M3BJ 280SMB	3GBJ286220-_DG706	32	90.5	920	0.91	1.3	2.2	260	650
31	M3BJ 315SMC	3GBJ316230-_DG706	46	91.5	1377	0.92	1.4	3.9	260	880
44	M3BJ 315MLA	3GBJ316410-_DG706	62	92.8	1928	0.94	1.4	5.8	260	1115
56	M3BJ 315LKB	3GBJ316820-_DG706	80	93.4	2447	0.92	1.5	7.8	260	1415
69	M3BJ 315LKC	3GBJ316830-_DG706	102	93.6	3058	0.91	1.5	9.8	260	1590
69	M3BJ 355SMB	3GBJ356220-_DG706	96	93.8	3050	0.96	1.8	17.1	260	1765
104	M3BJ 355MLB	3GBJ356420-_DG706	143	94.1	4572	0.96	1.6	22.4	260	2190
128	M3BJ 355LKB	3GBJ356820-_DG706	178	94.5	5636	0.95	1.7	28.5	260	2670
153	M3BJ 400LC	3GBJ406530-_DG706	205	95.3	6730	0.98	1.5	41.1	260	3260
2)	AMZ 0500L_10 RAM									
2)	AMZ 0560L_10 RAM									
n_n = 275 r/min										
24	M3BJ 280SMB	3GBJ286220-_DG705	38	91.4	844	0.88	1.4	2.2	330	650
36	M3BJ 315SMC	3GBJ316230-_DG705	56	92.4	1265	0.89	1.5	3.9	330	880
54	M3BJ 315MLA	3GBJ316410-_DG705	80	93.5	1886	0.91	1.5	5.8	330	1115
66	M3BJ 315LKB	3GBJ316820-_DG705	92	94.0	2291	0.95	1.5	7.8	330	1415
90	M3BJ 315LKC	3GBJ316830-_DG705	131	94.1	3115	0.91	1.5	9.8	330	1590
89	M3BJ 355SMB	3GBJ356220-_DG705	126	94.2	3096	0.94	1.7	17.1	330	1765
119	M3BJ 355MLB	3GBJ356420-_DG705	168	94.4	4120	0.93	1.7	22.4	330	2190
148	M3BJ 355LKB	3GBJ356820-_DG705	200	94.9	5145	0.97	1.7	28.5	330	2670
179	M3BJ 400LC	3GBJ406530-_DG705	239	95.6	6210	0.98	1.6	41.1	330	3260
2)	AMZ 0500L_10 RAM									
2)	AMZ 0560L_10 RAM									
n_n = 310 r/min										
31	M3BJ 280SMB	3GBJ286220-_DG707	46	92.1	964	0.92	1.3	2.2	372	650
44	M3BJ 315SMC	3GBJ316230-_DG707	62	93.4	1346	0.95	1.4	3.9	372	880
69	M3BJ 315MLA	3GBJ316410-_DG707	99	94.0	2134	0.93	1.4	5.8	372	1115
87	M3BJ 315LKB	3GBJ316820-_DG707	122	94.5	2668	0.94	1.4	7.8	372	1415
111	M3BJ 315LKC	3GBJ316830-_DG707	156	94.8	3415	0.94	1.4	9.8	372	1590
104	M3BJ 355SMB	3GBJ356220-_DG707	138	94.8	3196	0.99	1.6	17.1	372	1765
152	M3BJ 355MLB	3GBJ356420-_DG707	217	95.2	4669	0.92	1.7	22.4	372	2190
193	M3BJ 355LKB	3GBJ356820-_DG707	263	95.4	5952	0.96	1.6	28.5	372	2670
232	M3BJ 400LC	3GBJ406530-_DG707	339	95.9	7134	0.89	1.6	41.1	372	3260
2)	AMZ 0500L_10 RAM									
2)	AMZ 0560L_10 RAM									

¹⁾ See ordering information - section for details on motor type and product code

²⁾ Performance values for IEC frame sizes 500 and 560 on request

³⁾ T_{max}/T_n value represents maximum short time overloadability with inverter supply. This does not represent the pull-out torque according to IEC.

Permanent magnet synchronous motors

500 V Technical data

IC 411: Self ventilated motors

Loadability according to Figure 1 on page 6

Network voltage 500 V, at motor terminals 463 V

Output kW	Type designation ¹⁾	Product code ¹⁾	Current I _N A	Efficiency Full load %	Torque T _N Nm	Power factor cos φ	Torque $\frac{T_{max}}{T_N}$ ³⁾	Moment of inertia J=1/4GD ² kgm ²	Maximum speed, n _{max} r/min	Weight approx. kg
n_n = 375 r/min										
36	M3BJ 280SMB	3GBJ286220-_DG706	55	92.8	924	0.90	1.3	2.2	450	650
54	M3BJ 315SMC	3GBJ316230-_DG706	80	93.8	1379	0.91	1.4	3.9	450	880
75	M3BJ 315MLA	3GBJ316410-_DG706	106	94.5	1913	0.93	1.4	5.8	450	1115
94	M3BJ 315LKB	3GBJ316820-_DG706	136	94.8	2392	0.91	1.6	7.8	450	1415
117	M3BJ 315LKC	3GBJ316830-_DG706	172	94.9	2969	0.89	1.6	9.8	450	1590
116	M3BJ 355SMB	3GBJ356220-_DG706	161	94.9	2965	0.95	1.8	17.1	450	1765
177	M3BJ 355MLB	3GBJ356420-_DG706	243	95.4	4504	0.95	1.6	22.4	450	2190
214	M3BJ 355LKB	3GBJ356820-_DG706	298	95.5	5454	0.94	1.7	28.5	450	2670
260	M3BJ 400LC	3GBJ406530-_DG706	346	96.2	6614	0.97	1.6	41.1	450	3260
2) AMZ 0500L_10 RAM										
2) AMZ 0560L_10 RAM										
n_n = 433 r/min										
47	M3BJ 280SMB	3GBJ286220-_DG708	69	93.4	1028	0.90	1.2	2.2	520	650
69	M3BJ 315SMC	3GBJ316230-_DG708	98	94.6	1530	0.93	1.3	3.9	520	880
92	M3BJ 315MLA	3GBJ316410-_DG708	125	95.0	2021	0.96	1.4	5.8	520	1115
111	M3BJ 315LKB	3GBJ316820-_DG708	161	95.3	2444	0.90	1.6	7.8	520	1415
139	M3BJ 315LKC	3GBJ316830-_DG708	189	95.5	3060	0.96	1.5	9.8	520	1590
138	M3BJ 355SMB	3GBJ356220-_DG708	190	95.6	3046	0.95	1.8	17.1	520	1765
232	M3BJ 355MLB	3GBJ356420-_DG708	316	95.9	5105	0.95	1.5	22.4	520	2190
246	M3BJ 355LKB	3GBJ356820-_DG708	321	95.9	5419	1.00	1.6	28.5	520	2670
326	M3BJ 400LC	3GBJ406530-_DG708	434	96.6	7185	0.97	1.5	41.1	520	3260
2) AMZ 0500L_10 RAM										
2) AMZ 0560L_10 RAM										
n_n = 538 r/min										
54	M3BJ 280SMB	3GBJ286220-_DG707	79	93.9	956	0.91	1.3	2.2	645	650
75	M3BJ 315SMC	3GBJ316230-_DG707	105	94.8	1326	0.94	1.4	3.9	645	880
118	M3BJ 315MLA	3GBJ316410-_DG707	168	95.3	2091	0.92	1.4	5.8	645	1115
146	M3BJ 315LKB	3GBJ316820-_DG707	205	95.5	2587	0.93	1.5	7.8	645	1415
186	M3BJ 315LKC	3GBJ316830-_DG707	259	95.7	3295	0.93	1.4	9.8	645	1590
172	M3BJ 355SMB	3GBJ356220-_DG707	228	95.7	3061	0.99	1.7	17.1	645	1765
249	M3BJ 355MLB	3GBJ356420-_DG707	357	95.8	4420	0.91	1.8	22.4	645	2190
318	M3BJ 355LKB	3GBJ356820-_DG707	431	96.1	5649	0.96	1.7	28.5	645	2670
372	M3BJ 400LC	3GBJ406530-_DG707	548	96.5	6612	0.88	1.8	41.1	645	3260
2) AMZ 0500L_10 RAM										
2) AMZ 0560L_10 RAM										
n_n = 750 r/min										
78	M3BJ 280SMB	3GBJ286220-_DG708	116	94.7	997	0.89	1.3	2.2	863	650
117	M3BJ 315SMC	3GBJ316230-_DG708	164	95.5	1485	0.93	1.3	3.9	863	880
152	M3BJ 315MLA	3GBJ316410-_DG708	206	95.8	1929	0.96	1.4	5.8	863	1115
175	M3BJ 315LKB	3GBJ316820-_DG708	255	95.7	2221	0.89	1.7	7.8	863	1415
221	M3BJ 315LKC	3GBJ316830-_DG708	301	96.0	2813	0.96	1.6	9.8	863	1590
213	M3BJ 355SMB	3GBJ356220-_DG708	296	95.7	2709	0.94	2.0	17.1	863	1765
377	M3BJ 355MLB	3GBJ356420-_DG708	513	96.3	4797	0.95	1.6	22.4	863	2190
391	M3BJ 355LKB	3GBJ356820-_DG708	509	96.3	4980	1.00	1.7	28.5	863	2670
528	M3BJ 400LC	3GBJ406530-_DG708	701	97.0	6728	0.97	1.6	41.1	863	3260
2) AMZ 0500L_10 RAM										
2) AMZ 0560L_10 RAM										

500 V

¹⁾ See ordering information - section for details on motor type and product code

²⁾ Performance values for IEC frame sizes 500 and 560 on request

³⁾ T_{max}/T_n value represents maximum short time overloadability with inverter supply. This does not represent the pull-out torque value according to IEC.

Permanent magnet synchronous motors

575 V Technical data

IC 411: Self ventilated motors

Loadability according to Figure 1 on page 6

Network voltage 575 V, at motor terminals 532 V

Output kW	Type designation ¹⁾	Product code ¹⁾	Current I _N A	Efficiency Full load %	Torque T _N Nm	Power factor cos φ	Torque $\frac{T_{max}}{T_N}$ ³⁾	Moment of inertia J=1/4GD ² kgm ²	Maximum speed, n _{max} r/min	Weight approx. kg
n_n = 183 r/min										
16	M3BJ 280SMB	3GBJ286220-_DG705	22	89.6	850	0.90	1.4	2.2	220	650
24	M3BJ 315SMC	3GBJ316230-_DG705	32	90.4	1277	0.90	1.5	3.9	220	880
37	M3BJ 315MLA	3GBJ316410-_DG705	47	91.9	1908	0.92	1.4	5.8	220	1115
45	M3BJ 315LKB	3GBJ316820-_DG705	55	92.5	2333	0.96	1.5	7.8	220	1415
61	M3BJ 315LKC	3GBJ316830-_DG705	77	92.8	3179	0.92	1.5	9.8	220	1590
61	M3BJ 355SMB	3GBJ356220-_DG705	74	93.0	3172	0.95	1.7	17.1	220	1765
81	M3BJ 355MLB	3GBJ356420-_DG705	100	93.3	4228	0.94	1.7	22.4	220	2190
101	M3BJ 355LKB	3GBJ356820-_DG705	120	93.8	5289	0.98	1.6	28.5	220	2670
122	M3BJ 400LC	3GBJ406530-_DG705	142	94.6	6360	0.98	1.6	41.1	220	3260
2)	AMZ 0500L_10 RAM									
2)	AMZ 0560L_10 RAM									
n_n = 249 r/min										
24	M3BJ 280SMB	3GBJ286220-_DG706	32	91.0	934	0.91	1.3	2.2	299	650
37	M3BJ 315SMC	3GBJ316230-_DG706	47	92.4	1399	0.92	1.4	3.9	299	880
51	M3BJ 315MLA	3GBJ316410-_DG706	63	93.4	1958	0.94	1.4	5.8	299	1115
65	M3BJ 315LKB	3GBJ316820-_DG706	82	93.8	2486	0.92	1.5	7.8	299	1415
81	M3BJ 315LKC	3GBJ316830-_DG706	103	94.0	3107	0.91	1.5	9.8	299	1590
81	M3BJ 355SMB	3GBJ356220-_DG706	97	94.3	3101	0.96	1.7	17.1	299	1765
121	M3BJ 355MLB	3GBJ356420-_DG706	145	94.5	4650	0.96	1.6	22.4	299	2190
150	M3BJ 355LKB	3GBJ356820-_DG706	181	94.8	5733	0.95	1.6	28.5	299	2670
178	M3BJ 400LC	3GBJ406530-_DG706	208	95.6	6838	0.98	1.5	41.1	299	3260
2)	AMZ 0500L_10 RAM									
2)	AMZ 0560L_10 RAM									
n_n = 316 r/min										
27	M3BJ 280SMB	3GBJ286220-_DG705	37	91.9	817	0.88	1.4	2.2	379	650
40	M3BJ 315SMC	3GBJ316230-_DG705	54	92.7	1221	0.88	1.5	3.9	379	880
60	M3BJ 315MLA	3GBJ316410-_DG705	77	93.8	1816	0.91	1.5	5.8	379	1115
73	M3BJ 315LKB	3GBJ316820-_DG705	88	94.2	2196	0.95	1.6	7.8	379	1415
99	M3BJ 315LKC	3GBJ316830-_DG705	126	94.5	2979	0.90	1.6	9.8	379	1590
98	M3BJ 355SMB	3GBJ356220-_DG705	120	94.4	2946	0.94	1.8	17.1	379	1765
129	M3BJ 355MLB	3GBJ356420-_DG705	160	94.6	3908	0.93	1.8	22.4	379	2190
162	M3BJ 355LKB	3GBJ356820-_DG705	190	95.0	4887	0.97	1.8	28.5	379	2670
196	M3BJ 400LC	3GBJ406530-_DG705	227	95.8	5926	0.98	1.7	41.1	379	3260
2)	AMZ 0500L_10 RAM									
2)	AMZ 0560L_10 RAM									
n_n = 357 r/min										
37	M3BJ 280SMB	3GBJ286220-_DG707	47	92.9	978	0.92	1.2	2.2	428	650
51	M3BJ 315SMC	3GBJ316230-_DG707	63	93.8	1367	0.95	1.4	3.9	428	880
81	M3BJ 315MLA	3GBJ316410-_DG707	101	94.4	2168	0.93	1.3	5.8	428	1115
101	M3BJ 315LKB	3GBJ316820-_DG707	124	94.9	2711	0.93	1.4	7.8	428	1415
130	M3BJ 315LKC	3GBJ316830-_DG707	158	95.1	3470	0.94	1.4	9.8	428	1590
121	M3BJ 355SMB	3GBJ356220-_DG707	140	95.1	3249	0.99	1.6	17.1	428	1765
178	M3BJ 355MLB	3GBJ356420-_DG707	221	95.4	4752	0.92	1.6	22.4	428	2190
226	M3BJ 355LKB	3GBJ356820-_DG707	268	95.6	6055	0.96	1.6	28.5	428	2670
271	M3BJ 400LC	3GBJ406530-_DG707	344	96.1	7254	0.89	1.6	41.1	428	3260
2)	AMZ 0500L_10 RAM									
2)	AMZ 0560L_10 RAM									

¹⁾ See ordering information - section for details on motor type and product code

²⁾ Performance values for IEC frame sizes 500 and 560 on request

³⁾ T_{max}/T_n value represents maximum short time overloadability with inverter supply. This does not represent the pull-out torque value according to IEC.

Permanent magnet synchronous motors

575 V Technical data

IC 411: Self ventilated motors

Loadability according to Figure 1 on page 6

Network voltage 575 V, at motor terminals 532 V

Output kW	Type designation ¹⁾	Product code ¹⁾	Current I _N A	Efficiency Full load %	Torque T _N Nm	Power factor cos φ	Torque $\frac{T_{max}}{T_N^{3)}$	Moment of inertia J=1/4GD ² kgm ²	Maximum speed, n _{max} r/min	Weight approx. kg
n_n = 431 r/min										
40	M3BJ 280SMB	3GBJ286220-_DG706	53	93.1	891	0.89	1.3	2.2	517	650
60	M3BJ 315SMC	3GBJ316230-_DG706	77	94.0	1327	0.90	1.4	3.9	517	880
83	M3BJ 315MLA	3GBJ316410-_DG706	102	94.8	1826	0.93	1.5	5.8	517	1115
102	M3BJ 315LKB	3GBJ316820-_DG706	129	94.9	2251	0.90	1.7	7.8	517	1415
125	M3BJ 315LKC	3GBJ316830-_DG706	162	95.1	2776	0.89	1.7	9.8	517	1590
125	M3BJ 355SMB	3GBJ356220-_DG706	150	95.0	2760	0.95	1.9	17.1	517	1765
191	M3BJ 355MLB	3GBJ356420-_DG706	229	95.5	4239	0.95	1.7	22.4	517	2190
229	M3BJ 355LKB	3GBJ356820-_DG706	278	95.6	5076	0.94	1.8	28.5	517	2670
282	M3BJ 400LC	3GBJ406530-_DG706	326	96.3	6235	0.97	1.7	41.1	517	3260
3) AMZ 0500L_10 RAM										
3) AMZ 0560L_10 RAM										
n_n = 498 r/min										
54	M3BJ 280SMB	3GBJ286220-_DG708	70	93.8	1044	0.89	1.2	2.2	598	650
81	M3BJ 315SMC	3GBJ316230-_DG708	100	94.7	1554	0.93	1.3	3.9	598	880
107	M3BJ 315MLA	3GBJ316410-_DG708	127	95.4	2053	0.96	1.3	5.8	598	1115
130	M3BJ 315LKB	3GBJ316820-_DG708	163	95.6	2484	0.90	1.5	7.8	598	1415
162	M3BJ 315LKC	3GBJ316830-_DG708	192	95.7	3109	0.96	1.5	9.8	598	1590
162	M3BJ 355SMB	3GBJ356220-_DG708	194	95.7	3099	0.95	1.8	17.1	598	1765
271	M3BJ 355MLB	3GBJ356420-_DG708	321	96.1	5194	0.95	1.5	22.4	598	2190
287	M3BJ 355LKB	3GBJ356820-_DG708	326	96.1	5510	1.00	1.5	28.5	598	2670
381	M3BJ 400LC	3GBJ406530-_DG708	441	96.7	7302	0.97	1.5	41.1	598	3260
2) AMZ 0500L_10 RAM										
2) AMZ 0560L_10 RAM										
n_n = 618 r/min										
59	M3BJ 280SMB	3GBJ286220-_DG707	75	94.3	912	0.91	1.3	2.2	742	650
81	M3BJ 315SMC	3GBJ316230-_DG707	99	95.1	1255	0.94	1.5	3.9	742	880
127	M3BJ 315MLA	3GBJ316410-_DG707	158	95.4	1968	0.92	1.5	5.8	742	1115
156	M3BJ 315LKB	3GBJ316820-_DG707	190	95.6	2406	0.93	1.6	7.8	742	1415
198	M3BJ 315LKC	3GBJ316830-_DG707	240	95.8	3061	0.93	1.5	9.8	742	1590
183	M3BJ 355SMB	3GBJ356220-_DG707	209	95.7	2821	0.99	1.8	17.1	742	1765
259	M3BJ 355MLB	3GBJ356420-_DG707	327	95.8	4000	0.90	1.9	22.4	742	2190
334	M3BJ 355LKB	3GBJ356820-_DG707	394	96.1	5156	0.96	1.8	28.5	742	2670
387	M3BJ 400LKC	3GBJ406830-_DG707	503	96.5	5984	0.87	1.9	41.1	742	3260
2) AMZ 0500L_10 RAM										
2) AMZ 0560L_10 RAM										
nn = 863 r/min										
84	M3BJ 280SMB	3GBJ286220-_DG708	109	94.8	931	0.89	1.4	2.2	863	650
125	M3BJ 315SMC	3GBJ316230-_DG708	153	95.6	1387	0.93	1.4	3.9	863	880
159	M3BJ 315MLA	3GBJ316410-_DG708	188	95.8	1765	0.96	1.5	5.8	863	1115
173	M3BJ 315LKB	3GBJ316820-_DG708	224	95.4	1919	0.88	2.0	7.8	863	1415
224	M3BJ 315LKC	3GBJ316830-_DG708	265	95.8	2474	0.96	1.8	9.8	863	1590
207	M3BJ 355SMB	3GBJ356220-_DG708	253	95.3	2287	0.93	2.4	17.1	863	1765
388	M3BJ 355MLB	3GBJ356420-_DG708	460	96.3	4294	0.95	1.8	22.4	863	2190
395	M3BJ 355LKB	3GBJ356820-_DG708	446	96.1	4367	1.00	1.9	28.5	863	2670
543	M3BJ 400LC	3GBJ406530-_DG708	624	96.9	6011	0.97	1.8	41.1	863	3260
2) AMZ 0500L_10 RAM										
2) AMZ 0560L_10 RAM										

¹⁾ See ordering information - section for details on motor type and product code
²⁾ Performance values for IEC frame sizes 500 and 560 on request

³⁾ T_{max}/T_n value represents maximum short time overloadability with inverter supply. This does not represent the pull-out torque value according to IEC.

Permanent magnet synchronous motors

690 V Technical data

IC 411: Self ventilated motors

Loadability according to Figure 1 on page 6

Network voltage 690 V, at motor terminals 638 V

Output kW	Type designation ¹⁾	Product code ¹⁾	Current I_N A	Efficiency Full load 100 %	Torque T_N Nm	Power factor cos φ	Torque $\frac{T_{max}}{T_N}$ ³⁾	Moment of inertia $J=1/4GD^2$ kgm ³	Maximum speed, n_{max} r/min	Weight approx. kg
$n_n = 220$ r/min										
20	M3BJ 280SMB	3GBJ286220-_DG705	22	90.0	868	0.90	1.3	2.2	220	650
30	M3BJ 315SMC	3GBJ316230-_DG705	33	91.5	1306	0.90	1.4	3.9	220	880
45	M3BJ 315MLA	3GBJ316410-_DG705	48	92.6	1952	0.92	1.4	5.8	220	1115
55	M3BJ 315LKB	3GBJ316820-_DG705	56	93.2	2385	0.95	1.5	7.8	220	1415
75	M3BJ 315LKC	3GBJ316830-_DG705	79	93.5	3252	0.91	1.4	9.8	220	1590
75	M3BJ 355SMB	3GBJ356220-_DG705	76	93.5	3250	0.95	1.6	17.1	220	1765
99	M3BJ 355MLB	3GBJ356420-_DG705	102	93.9	4332	0.94	1.7	22.4	220	2190
124	M3BJ 355LKB	3GBJ356820-_DG705	122	94.2	5418	0.98	1.6	28.5	220	2670
149	M3BJ 400LC	3GBJ406530-_DG705	145	95.1	6503	0.98	1.5	41.1	220	3260
2)	AMZ 0500L_10 RAM									
2)	AMZ 0560L_10 RAM									
$n_n = 300$ r/min										
30	M3BJ 280SMB	3GBJ286220-_DG706	33	92.0	954	0.90	1.3	2.2	300	650
45	M3BJ 315SMC	3GBJ316230-_DG706	48	92.9	1431	0.91	1.3	3.9	300	880
63	M3BJ 315MLA	3GBJ316410-_DG706	65	93.9	2003	0.94	1.4	5.8	300	1115
80	M3BJ 315LKB	3GBJ316820-_DG706	84	94.3	2544	0.91	1.5	7.8	300	1415
100	M3BJ 315LKC	3GBJ316830-_DG706	106	94.4	3181	0.90	1.5	9.8	300	1590
99	M3BJ 355SMB	3GBJ356220-_DG706	100	94.6	3177	0.96	1.7	17.1	300	1765
149	M3BJ 355MLB	3GBJ356420-_DG706	149	94.9	4763	0.96	1.5	22.4	300	2190
184	M3BJ 355LKB	3GBJ356820-_DG706	185	95.1	5881	0.95	1.6	28.5	300	2670
219	M3BJ 400LC	3GBJ406530-_DG706	212	95.8	6991	0.97	1.5	41.1	300	3260
2)	AMZ 0500L_10 RAM									
2)	AMZ 0560L_10 RAM									
$n_n = 380$ r/min										
31	M3BJ 280SMB	3GBJ286220-_DG705	35	92.2	770	0.87	1.5	2.2	380	650
46	M3BJ 315SMC	3GBJ316230-_DG705	51	93.2	1145	0.87	1.6	3.9	380	880
67	M3BJ 315MLA	3GBJ316410-_DG705	72	94.1	1696	0.90	1.6	5.8	380	1115
81	M3BJ 315LKB	3GBJ316820-_DG705	82	94.5	2032	0.94	1.7	7.8	380	1415
109	M3BJ 315LKC	3GBJ316830-_DG705	117	94.7	2745	0.89	1.7	9.8	380	1590
107	M3BJ 355SMB	3GBJ356220-_DG705	110	94.4	2688	0.93	2.0	17.1	380	1765
141	M3BJ 355MLB	3GBJ356420-_DG705	147	94.8	3545	0.92	2.0	22.4	380	2190
177	M3BJ 355LKB	3GBJ356820-_DG705	173	95.1	4444	0.97	2.0	28.5	380	2670
217	M3BJ 400LC	3GBJ406530-_DG705	208	95.9	5448	0.98	1.8	41.1	380	3260
2)	AMZ 0500L_10 RAM									
2)	AMZ 0560L_10 RAM									
$n_n = 430$ r/min										
45	M3BJ 280SMB	3GBJ286220-_DG707	48	93.3	999	0.91	1.2	2.2	430	650
63	M3BJ 315SMC	3GBJ316230-_DG707	64	94.3	1398	0.94	1.3	3.9	430	880
100	M3BJ 315MLA	3GBJ316410-_DG707	103	94.9	2218	0.92	1.3	5.8	430	1115
124	M3BJ 315LKB	3GBJ316820-_DG707	127	95.2	2773	0.93	1.4	7.8	430	1415
159	M3BJ 315LKC	3GBJ316830-_DG707	162	95.4	3550	0.93	1.3	9.8	430	1590
149	M3BJ 355SMB	3GBJ356220-_DG707	144	95.4	3329	0.99	1.5	17.1	430	1765
219	M3BJ 355MLB	3GBJ356420-_DG707	226	95.6	4875	0.92	1.6	22.4	430	2190
279	M3BJ 355LKB	3GBJ356820-_DG707	274	95.9	6210	0.96	1.5	28.5	430	2670
332	M3BJ 400LC	3GBJ406530-_DG707	351	96.3	7399	0.89	1.6	41.1	430	3260
2)	AMZ 0500L_10 RAM									
2)	AMZ 0560L_10 RAM									

¹⁾ See ordering information - section for details on motor type and product code

²⁾ Performance values for IEC frame sizes 500 and 560 on request

³⁾ T_{max}/T_n value represents maximum short time overloadability with inverter supply. This does not represent the pull-out torque value according to IEC.

Permanent magnet synchronous motors

690 V Technical data

IC 411: Self ventilated motors

Loadability according to Figure 1 on page 6

Network voltage 690 V, at motor terminals 638 V

Output kW	Type designation ¹⁾	Product code ¹⁾	Current I _N A	Efficiency Full load %	Torque T _N Nm	Power factor cos φ	Torque $\frac{T_{max}}{T_N^{3)}$	Moment of inertia J=1/4GD ² kgm ²	Maximum speed, n _{max} r/min	Weight approx. kg
n_n = 518 r/min										
45	M3BJ 280SMB	3GBJ286220-_DG706	49	93.4	833	0.89	1.4	2.2	518	650
67	M3BJ 315SMC	3GBJ316230-_DG706	72	94.4	1235	0.90	1.6	3.9	518	880
91	M3BJ 315MLA	3GBJ316410-_DG706	93	94.9	1675	0.93	1.6	5.8	518	1115
109	M3BJ 315LKB	3GBJ316820-_DG706	116	94.9	2007	0.89	1.9	7.8	518	1415
132	M3BJ 315LKC	3GBJ316830-_DG706	145	95.0	2442	0.87	1.9	9.8	518	1590
130	M3BJ 355SMB	3GBJ356220-_DG706	132	94.9	2406	0.94	2.2	17.1	518	1765
205	M3BJ 355MLB	3GBJ356420-_DG706	206	95.5	3786	0.95	1.9	22.4	518	2190
240	M3BJ 355LKB	3GBJ356820-_DG706	245	95.5	4429	0.93	2.1	28.5	518	2670
304	M3BJ 400LC	3GBJ406530-_DG706	292	96.4	5605	0.98	1.8	41.1	518	3260
2)	AMZ 0500L_10 RAM									
2)	AMZ 0560L_10 RAM									
n_n = 600 r/min										
67	M3BJ 280SMB	3GBJ286220-_DG708	72	94.4	1067	0.89	1.2	2.2	600	650
100	M3BJ 315SMC	3GBJ316230-_DG708	102	95.1	1590	0.93	1.2	3.9	600	880
131	M3BJ 315MLA	3GBJ316410-_DG708	130	95.6	2099	0.95	1.3	5.8	600	1115
159	M3BJ 315LKB	3GBJ316820-_DG708	167	95.7	2543	0.90	1.5	7.8	600	1415
199	M3BJ 315LKC	3GBJ316830-_DG708	197	95.9	3180	0.95	1.4	9.8	600	1590
199	M3BJ 355SMB	3GBJ356220-_DG708	199	95.9	3178	0.95	1.7	17.1	600	1765
333	M3BJ 355MLB	3GBJ356420-_DG708	329	96.2	5323	0.95	1.4	22.4	600	2190
353	M3BJ 355LKB	3GBJ356820-_DG708	334	96.2	5639	0.99	1.5	28.5	600	2670
467	M3BJ 400LC	3GBJ406530-_DG708	451	96.9	7468	0.97	1.4	41.1	600	3260
2)	AMZ 0500L_10 RAM									
2)	AMZ 0560L_10 RAM									
n_n = 742 r/min										
65	M3BJ 280SMB	3GBJ286220-_DG707	69	94.3	834	0.91	1.5	2.2	742	650
88	M3BJ 315SMC	3GBJ316230-_DG707	89	95.1	1134	0.94	1.6	3.9	742	880
136	M3BJ 315MLA	3GBJ316410-_DG707	141	95.5	1756	0.92	1.7	5.8	742	1115
163	M3BJ 315LKB	3GBJ316820-_DG707	167	95.5	2092	0.93	1.8	7.8	742	1415
207	M3BJ 315LKC	3GBJ316830-_DG707	210	95.6	2658	0.93	1.8	9.8	742	1590
187	M3BJ 355SMB	3GBJ356220-_DG707	179	95.4	2409	0.99	2.1	17.1	742	1765
255	M3BJ 355MLB	3GBJ356420-_DG707	277	95.4	3278	0.87	2.4	22.4	742	2190
335	M3BJ 355LKB	3GBJ356820-_DG707	332	95.7	4313	0.95	2.2	28.5	742	2670
384	M3BJ 400LC	3GBJ406530-_DG707	431	96.2	4940	0.84	2.4	41.1	742	3260
2)	AMZ 0500L_10 RAM									
2)	AMZ 0560L_10 RAM									

¹⁾ See ordering information - section for details on motor type and product code

²⁾ Performance values for IEC frame sizes 500 and 560 on request

³⁾ T_{max}/T_n value represents maximum short time overloadability with inverter supply. This does not represent the pull-out torque value according to IEC.

Permanent magnet motors, frame sizes 280 to 400 - Variant codes

Code ¹⁾	Variant	280	315	355 to 400
Balancing				
424	Full key balancing.	P	P	P
Bearings and lubrication				
036	Transport lock for bearings.	M	M	M
037	Roller bearing at D-end.	R	R	R
039	Cold resistant grease. For bearing temperatures -55 - + 100°C	M	M	M
041	Bearings regreasable via grease nipples.	S	S	S
042	Locked drive-end.	S	S	S
043	SPM nipples.	S	S	S
058	Angular contact ball bearing at D-end, shaft force away from bearing	R	R	R
059	Angular contact ball bearing at N-end, shaft force towards bearing	R	R	R
060	Angular contact bearing at D-end, shaft force towards bearing	R	R	R
061	Angular contact bearing at N-end, shaft force away from bearing	R	R	R
107	Bearing mounted Pt-100 resistance elements.	P	P	P
108	Continuous bearing monitoring (SPM CMM).	P	P	P
420	Bearing mounted PTC thermistors.	P	P	P
701	Insulated bearing at N-end	S	S	S
Branch standard designs				
178	Stainless steel/acid proof bolts.	M	M	M
209	Non-standard voltage or frequency (special winding).	R	R	R
419	Textile industry design.	R	R	R
425	Corrosion protected stator and rotor core.	P	P	P
785	Reinforced tropicalization.	R	R	R
Cooling system				
068	Metal fan.			
	Mandatory for ambient temperatures $\geq 60^{\circ}\text{C}$.	P	P	P
183	Separate motor cooling (fan axial, N-end).	P	P	P
422	Separate motor cooling (fan top or side, N-end).	P	P	P
791	Stainless steel fan cover.	P	P	P
Coupling				
035	Assembly of customer supplied coupling-half (finish bored and balanced).	R	R	R
Dimension drawing				
141	Binding dimension drawing.	M	M	M
Drain holes				
065	Plugged existing drain holes.	M	M	M
066	Modified drain hole position (for specified IM xxxx).	M	M	M
076	Draining holes with plugs.	S	S	S
Earthing bolt				
067	External earthing bolt.	S	S	S
Heating elements				
450	Heating element, 100 - 120 V.	M	M	M
451	Heating element, 200 - 240 V.	M	M	M

¹⁾ Certain variant codes cannot be used simultaneously.

S = Included as standard
M = On modification of a stocked motor, or on new manufacture, the number per order may be limited.

P = New manufacture only.
R = On request.
NA = Not applicable

Code ¹⁾	Variant	280	315	355 to 400
Insulation system				
014	Winding insulation class H.	P	P	P
405	Special winding insulation for frequency converter supply,	S	S	S
406	Winding for supply > 690 ≤ 1000 V.	R	R	R
Mounting arrangements				
009	IM 2001 foot/flange mounted, IEC flange, from IM 1001 (B35 from B3).	R	R	R
Noise reduction				
055	Noise reducing cover	P	P	P
Painting				
111	Offshore two-pack polyamide cured epoxy paint 160 mm	P	P	P
114	Special paint colour, standard grade.	M	M	M
115	Offshore zink primer painting.	R	R	R
179	Special paint specification.	R	R	R
Protection				
072	Radial seal at D-end.	M	M	M
073	Sealed against oil at D-end.	R	R	R
005	Protective roof, vertical motor, shaft down.	M	M	M
401	Protective roof, horizontal motor.	P	P	P
403	Degree of protection IP 56.	M	M	M
783	Labyrinth sealing at D-end.	M	M	M
Rating & instruction plates				
002	Restamping voltage, frequency and output, continuous duty.	R	R	R
135	Mounting of additional identification plate, stainless.	M	M	M
138	Mounting of additional identification plate, aluminium.	M	M	M
139	Additional identification plate delivered loose.	M	M	M
150	Instruction plate and maintenance instructions in non-standard language	R	R	R
161	Additional rating plate delivered loose.	M	M	M
163	Additional frequency converter rating plate fixed to stator	M	M	M
Shaft & rotor				
069	Two shaft extensions as per basic catalogue.	P	P	P
070	One or two special shaft extensions.	P	P	P
155	Cylindrical shaft extension, D-end, without key-way.	P	P	P
156	Cylindrical shaft extension, N-end, without key-way.	P	P	P
164	Shaft extension with closed key-way.	P	P	P
165	Shaft extension with open key-way.	S	S	S
410	Stainless/acid-proof steel shaft (standard or			
427	Shaft extension complies with Australian Standards (AS).	P	P	P
431	Special shaft material for low temperatures, -40°C.	P	P	P
Standards and regulations				
010	Fulfilling CSA Safety Certificate	R	R	R

¹⁾ Certain variant codes cannot be used simultaneously.

S = Included as standard
M = On modification of a stocked motor, or on new manufacture, the number per order may be limited.

P = New manufacture
R = On request.
NA = Not applicable

Code ¹⁾	Variant	280	315	355 to 400
Stator winding temperature sensors				
Breaking capacity for bimetal detector: Sizes 280 - 400				
121	Bimetal detectors, break type (NCC), (3 in series), 130°C, in stator winding.	M	M	M
122	Bimetal detectors, break type (NCC), (3 in series), 150°C, in stator winding.	M	M	M
123	Bimetal detectors, break type (NCC), (3 in series), 170°C, in stator winding.	M	M	M
125	Bimetal detectors, break type (NCC), (2x3 in series), 150°C, in stator winding.	M	M	M
127	Bimetal detectors, break type (NCC), (3 in series, 130°C and 3 in series, 150°C), in stator winding.	M	M	M
435	PTC - thermistors (3 in series), 130°C, in stator winding.	R	R	R
436	PTC - thermistors (3 in series), 150°C, in stator winding.	R	R	R
437	PTC - thermistors (3 in series), 170°C, in stator winding.	R	R	R
439	PTC - thermistors (2x3 in series), 150°C, in stator winding.	R	R	R
441	PTC - thermistors (3 in series, 130°C and 3 in series,	R	R	R
442	PTC - thermistors (3 in series, 150°C and 3 in series, 170°C, in stator winding.			M
445	PT100 (1 per phase) in stator winding.	S	S	S
446	PT100 (2 per phase) in stator winding.	M	M	M
Terminal box				
015	Motor supplied in D-connection.	M	M	M
017	Motor supplied in Y-connection.	M	M	M
019	Larger than standard terminal box.	R	R	R
021	Terminal box LHS (seen from D-end).	R	R	R
180	Terminal box RHS (seen from D-end).	R	R	R
137	Extended cable connection, low terminal box, "Flying leads".	P	P	R
230	Standard cable glands.	S	S	S
400	4 x 90 degr turnable terminal box.	P	P	M
402	Terminal box adapted for Al cables.	S	S	M
413	Extended cable connection, no terminal box	P	P	P
418	Separate terminal box for temperature detectors.	P	P	P
466	Terminal box at N-end.	P	P	P
704	EMC cable termination	M	M	M
729	Cable flange without holes / Blank gland plates	M	M	M
731	Two standard cable glands.	S	S	S
743	Painted steel flange for gable glands	M	M	M
744	Stainless steel flange for gable glands	M	M	M
Testing				
148	Routine test report.	M	M	M
760	Vibration level test.	M	M	M
761	Vibration spectrum test.	M	M	M
762	Noise level test.	M	M	M
763	Noise spectrum test.	M	M	M
764	Complete test with ABB frequency converter	M	M	M

¹⁾ Certain variant codes cannot be used simultaneously, only.

S = Included as standard
M = On modification of a stocked motor, or on new manufacture, the number per order may be limited.

P = New manufacture
R = On request.
NA = Not applicable

Code ¹⁾	Variant	280	315	355 to 400
Pulse tacho & separate cooling				
Cooling system				
183	Separate motor cooling (fan axial, N-end).	P	P	P
422	Separate motor cooling (fan top or side, N-end).	P	P	P
Mounting of tacho; tacho not included				
182	Pulse sensor mounted as specified (Leine & Linde equivalent, hollow-shaft type).	P	P	P
470	Prepared for hollow shaft pulse tacho (Leine&Linde equivalent).	P	P	P
479	Mounting of other types of tachos with shaft extension.	P	P	P
570	Prepared for hollow shaft pulse tacho (Leine&Linde 562)	P	P	P
Mounting of tacho; tacho included				
062	Tachogenerator.	P	P	P
471	512 hollow shaft pulse tacho (Leine&Linde equivalent) mounted.	P	P	P
472	1024 hollow shaft pulse tacho (Leine&Linde equivalent) mounted.	P	P	P
473	2048 hollow shaft pulse tacho (Leine&Linde equivalent) mounted.	P	P	P
572	1024 pulse tacho (Leine&Linde 562).	P	P	P
573	2048 pulse tacho (Leine&Linde 562).	P	P	P
748	Pulse tacho Lake Shore (RIM 8500) mounted.	P	P	P
749	Pulse tacho Avtron (M285) mounted.	P	P	P
Separate motor cooling & tacho; tacho not included				
474	Separate motor cooling and prepared for hollow shaft	P	P	P
478	Separate motor cooling (fan top, N-end) and prepared for hollow shaft pulse tacho (Leine & Linde equivalent).	P	P	P
574	Separate motor cooling (fan axial, N-end) and prepared for hollow shaft tacho (Leine & Linde 562)	P	P	P
578	Separate motor cooling, IP 44, 400 V, 50 Hz (fan axial, N-end) and prepared for hollow shaft tacho (Leine & Linde 562)	P	P	P
486	Separate motor cooling (fan top, N-end) and prepared for DC tacho.	P	P	P
487	Separate motor cooling (fan axial, N-end) and prepared for hollow shaft pulse tacho (Lake Shore RIM 8500 or Avtron M285).	P	P	P
Separate motor cooling & tacho; tacho included				
428	Separate motor cooling (fan top, N-end) and Leine & Linde, type 510006361, pulse tacho	P	P	P
429	Separate motor cooling (fan top, N-end) and Leine & Linde, type 861007455, hollow shaft pulse tacho	P	P	P
430	Separate motor cooling (fan top, N-end) and DC tacho, shaft extension type.	P	P	P
475	Separate motor cooling (fan axial, N-end) and 512 hollow shaft pulse tacho (Leine & Linde equivalent)	P	P	P
476	Separate motor cooling (fan axial, N-end) and 1024 hollow shaft pulse tacho (Leine & Linde equivalent)	P	P	P
477	Separate motor cooling (fan axial, N-end) and 2048 hollow shaft pulse tacho (Leine & Linde equivalent)	P	P	P
488	Separate motor cooling (fan axial, N-end) and Lake Shore RIM 8500 pulse tacho mounted.	P	P	P
489	Separate motor cooling (fan axial, N-end) and Avtron M285 pulse tacho mounted.	P	P	P
576	Separate motor cooling (fan axial, N-end) and 1024 pulse tacho (L&L 562).	P	P	P
577	Separate motor cooling (fan axial, N-end) and 2048 pulse tacho (L&L 562).	P	P	P
580	Separate motor cooling, IP 44, 400 V, 50 Hz (fan axial, N-end) and 1024 pulse tacho (Leine & Linde 562).	P	P	P
581	Separate motor cooling, IP 44, 400 V, 50 Hz (fan axial, N-end) and 2048 pulse tacho (Leine & Linde 562).	P	P	P

¹⁾ Certain variant codes cannot be used simultaneously.

S = Included as standard
M = On modification of a stocked motor, or on new manufacture, the number per order may be limited.

P = New manufacture only.
R = On request.
NA = Not applicable

Permanent magnet motors, standard construction for motors 500 and 560

Standard construction

Stator frame

- Cast iron EN-GJL-200 SFS-EN 1561

Bearing shields

- Cast iron EN-GLJ-200 SFS-EN 1561

Bearings

- Ball bearings
- Bearing insulation at N-end
- Bearings protection: Pt-100 1 pcs/bearing, 3-wire connection
- **500**
IM 1001: D-end 6330/C3, N-end 6330/C3
IM 3011: D-end 6330/C3, N-end 7330 BM
- **560**
IM 1001: D-end 6338/C3, N-end 6338/C3
IM 3011: D-end 6338/C3, N-end 7338 BM

Axially locked bearings

- Axially locked at D-end in horizontal machine
- Axially locked at N-end in vertical machine

Bearing seal

- Labyrinth seal in both ends

Lubrication

- Regreasable bearings
- Grease nipple M10x1 DIN 71412

SPM-nipples

- 1 pcs/bearing

Rating and lubrication plate

- Stainless steel, EN 10088, thickness 0.5 mm

Main terminal box

- Structural steel S235JRG2 – EN 10025, thickness 3 mm
- Screws: Steel 8.8, Delta-Tone 9000

Connections

- Cable entries:
 - Undrilled gland plate
 - Roxtec EMC cable entry
 - Grounding locations on frame and terminal box (in- and outside)

Auxiliary terminal box

- Material: aluminium
- Cable entries: M20 x 1.5 (2 pcs)
- Cable glands: included as standard
 - Material: nickel plated brass

Fan

- Structural steel S235JRG2 – EN 10025

Fan cover

- Structural steel S235JRG2 – EN 10025, thickness 3 mm

Stator winding

- Form wound copper
- Insulation class F (155 °C)
- Winding protection: Pt-100 6 pieces, 3-wire connection

Rotor

- Permanent magnet rotor

Shaft

- One open keyway
- Shaft material: 42CrMo4 - EN 10083

Balancing

- Rotor balanced with half key according to ISO 1940/1
 - Balancing grade G2.5

Drain holes

- Drain holes at lowest part of the machine-
 - IM 1001 2 pcs in frame
 - IM 3011 2 pcs in D-end shield

Cooling

- IC411
- IC416 (axially mounted blower unit)

Mounting

- IM 1001 (horizontal machine)
- IM 3011 (vertical machine, shaft downwards)

Ambient temperature

- -20 to +40°C

Altitude

- ≤ 1000 m above sea level

Protection

- IP55

Application related standards:

- EMC

Painting

- Paint System 1
 - Standard BS 5493
 - Colour Munsell 8B 4.5/3.25 / NCS 4822 B05G
 - Two-pack epoxy paint, thickness ≥ 180 µm

Standard documentation

- Dimension drawing
- Connection diagram (main, auxiliary)
- Performance data of motor
- Maintenance manual
- Routine test report

Standard tests

- Routine test

Permanent magnet motors, optional construction for motors 500 and 560

Optional specification

Mounting

- IM 1002
 - Max. torque limited for N-end shaft
- IM 2001

Cooling

- IC 416
 - top mounted blower unit, only for horizontal machines
- IC 417

Ambient temperature

- Min limit -50 to -20 °C, to be checked case by case
- Max limit +40 to +60 °C, to be checked case by case

Protection

- IP56

Local or application related standards

- SD-CSA
 - Standard CSA
- SD-LRS
 - Standard LRS
- SD-DNV
 - Standard DnV
- SD-GL
 - Standard GL
- SD-BV
 - Standard BV
- SD-RINA
 - Standard RINA

Optional constructions

Balancing

- BL-SET
 - Rotor balanced with full key

Shaft

- CM-SET
 - Machined coupling half, mounting only

Bearings

- IN-SET1
 - Inpro-seal in D-end
- IN-SET2
 - Inpro-seal in N-end
- IN-SET3
 - Inpro-seal in D- and N-end
- GC-SET
 - Grease collector in D- and/or N-end
- IB-SET
 - Both bearings insulated, earth strap in D-end
- TL-SET
 - Transport locking device

Main terminal box

- MT-SET1
 - Main terminal box in N-end (horizontal machines)
- MG-SET1
 - Cable glands for supply cables: Hawke
- MG-SET2
 - Provision for cable glands (no Roxtec): M-threads

Auxiliary terminal boxes

- AS-SET
 - Separate terminal box for space heater and RTD's
- AM-SET
 - Special material: stainless steel AISI 304
- AG-SET1
 - Cable glands for control cables: Hawke

Others

- PS-SET2
 - Paint system 2
- PS-SET4
 - Paint system 4
- DH-SET
 - Threaded drain plug in frame
- SS-SET
 - Bolts, nuts and washers made of stainless steel

Optional accessories

Control and protective equipment

General

- RT-SET1
 - RTD's with 4-wire connection
- RT-SET2
 - Duplex RTD's with 4-wire connection

Winding

- PY-SET1
 - Thermistors (PTC), 3 pcs set temperature 150 °C and 3 pcs 170 °C.
- TT-PT100-SET1
 - Transmitters for Pt-100, 3 pcs

Bearings

- AFB-TCK-SET1
 - Thermocouples, 1 pcs/bearing, type K (NiCr-Ni)
- AFB-TCT-SET1
 - Thermocouples, 1 pcs/bearing, type T (Cu-CuNi)
- AFB-TCJ-SET1
 - Thermocouples, 1 pcs/bearing, type J (Fe-CuNi)
- AFB-TCE-SET1
 - Thermocouples, 1 pcs/bearing, type E (NiCr-CuNi)
- TT-PT100-SET2
 - Transmitters for Pt-100 3 pcs for windings and 1 pc for each bearing
- TT-TC-SET1
 - Transmitters for thermocouple, 1 pc for each bearing
- AFB-DAT-SET1-HX
 - Dial type thermometer without contacts, 1 pcs/bearing
- AFB-DATC-SET1
 - Dial type thermometer with contacts, 1 pcs/bearing

Heating elements

- Single phase, 50/60 Hz, 400 W (AMZ 0500)
or 500 W (AMZ 0560)
- RE-SET1
 - Voltage range: 220 to 250 V
 - RE-SET2-
 - Voltage range: 110 to 120 V
 - RE-SET3
 - Voltage range: 380 to 440 V

Pulse encoder

ABB standard type

- TAC-SET1
 - Pulse rate 1024 ppr
- TAC-SET2
 - Pulse rate 2048 ppr

Vibration transducers

- VIB-SPM-SET2-HX
 - Seismic type accelerometers mounted on the end shields, 2 pcs. Measuring direction horizontal.
- VIB-SPM-SET3-HX
 - 1 pc accelerometer mounted on end shield. Measuring direction axial.

Foundation and site equipment

Foot mounting only

- MB-SET-1
 - Mounting bolts (1 pc/foot or 8 pcs/flange)
- ZBSFBP
 - Adjusting screw package for concrete foundation
- DP-SET1
 - Dowel pins, 2 pcs
- ZBA-SET1
 - Shim package of stainless steel
- ZBA-SET2
 - Shims, 2 mm, 4 pcs
- FOST-SET
 - Foundation studs with anchor bolts, 1 pc/foot
- SOPL-A-SET
 - Sole plates with anchor bolts, 1 pc/motor side
- SOPL-SET
 - Sole plates without anchor bolts, 1 pc/motor side

Others

- RC-SET
 - Rain canopy for vertical machines

Optional documentation

- Main terminal box drawing
- Auxiliary terminal box drawing
- Rotor drawing

Optional tests

- Type test

Special construction

Note! All special constructions must be checked at the factory case by case.

Special specification

Cooling

- IC 71W
 - Water cooled, welded frame construction

Special constructions

Shaft

- SE-SET1
 - Special shaft extension at D-end, only motor size 500 (not applicable for foot- and flange mounted machine):
D=160 mm, E=300 mm
- SE-SET2
 - Smaller shaft extension at D-end.
- TE-SET
 - Tapered shaft

Main terminal box

- MT-SET2
 - Main terminal box on right or left side of the machine
- MM-SET1
 - Special material: hot zinc coated
- MM-SET2
 - Special material: stainless steel AISI 304

Fan

- FM-SET1
 - Special material: aluminium
- FM-SET2
 - Special material: stainless steel AISI 304

Control and protective equipment

- CU-SET
 - Winding protection: Cu10, 6 pcs 3-wire connection
- PI-SET
 - Pt100 in motor air circuit: 1 pc in D-end 3 wire connection

Others

- BR-SET1
 - Brakes
- BR-SET2
 - Backstops

Permanent magnet motors

Cooling designation: IC 411

Sizes 280-315

Dimension drawings

Foot-mounted: IM B3 (IM 1001)

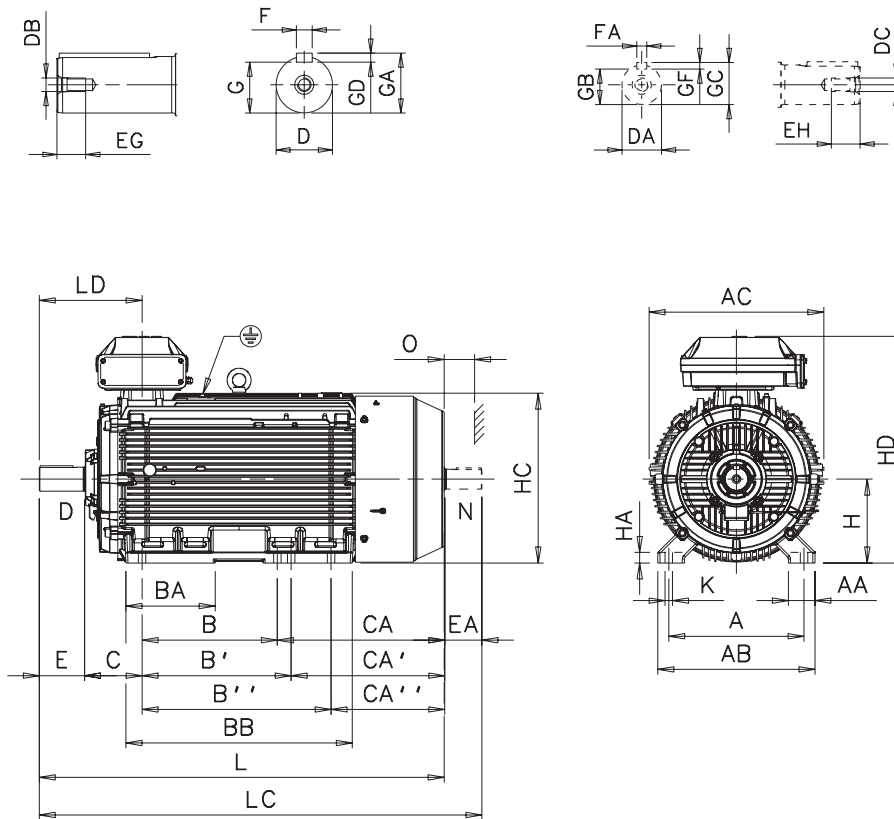

Motor size	A	AA	AB	AC	B	B'	B''	BA	BB	C	CA	CA'	CA''	D	DA	DB	DC	E	EA	EG	EH
280 SM_	457	84	530	577	368	419	-	147	506	190	400	349	-	75	65	M20	M20	140	140	40	40
315 SM_	508	100	590	654	406	457	-	180	558	216	420	369	-	80	75	M20	M20	170	140	40	40
315 ML_	508	100	590	654	457	508	-	212	669	216	480	429	-	90	75	M24	M20	170	140	48	40
315 LK_	508	100	590	654	508	560	710	336	851	216	635	583	433	90	75	M24	M20	170	140	48	40

Motor size	F	FA	G	GA	GB	GC	GD	GF	H	HA	HC	HD ¹⁾	HD ²⁾	K	L	LC	LD	O
280 SM_	20	18	67.5	79.5	58	69	12	11	280	31	564	762	-	24	1088	1236	336	100
315 SM_	22	20	71	85	67.5	79.5	14	12	315	40	639	852	-	28	1204	1352	386	115
315 ML_	25	20	81	95	67.5	79.5	14	12	315	40	639	852	-	28	1315	1463	386	115
315 LK_	25	20	81	95	67.5	79.5	14	12	315	40	639	852	880	28	1521	1669	386	115

Tolerances:

A, B	± 0,8	F	ISO h9
C, CA	± 0,8	H	+0 -0,5
D	ISO k6 < Ø 50mm ISO m6 > Ø 50mm	N	ISO j6

¹⁾ Terminal box 370

²⁾ Terminal box 750

Above table gives the main dimensions in mm.

For detailed drawings please see our web site
'www.abb.com/motors&drives' or contact us.

Permanent magnet motors

Sizes 355-400

Cooling designation: IC 411

Dimension drawings

Foot-mounted: IM B3 (IM 1001)

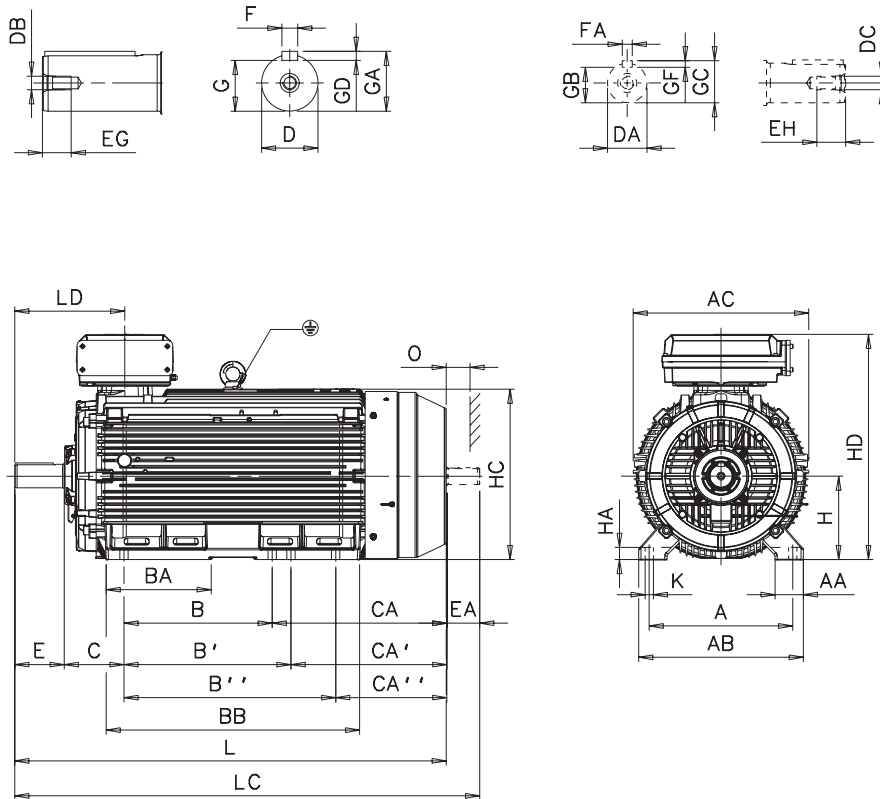

Motor size	A	AA	AB	AC	B	B'	B''	BA	BB	C	CA	CA'	CA''	D	DA	DB	DC	E	EA	EG	EH
355 SM_	610	120	700	746	500	560	-	221	722	254	525	465	-	100	90	M24	M24	210	170	50	48
355 ML_	610	120	700	746	560	630	-	267	827	254	500	570	-	100	90	M24	M24	210	170	50	48
355 LK_	610	120	700	746	630	710	900	447	1077	254	750	670	480	100	90	M24	M24	210	170	50	48
400 L_	710	150	840	834	900	1000	-	410	1156	224	567	467	-	110	90	M24	M24	210	170	50	48

Motor size	F	FA	G	GA	GB	GC	GD	GF	H	HA	HC	HD ¹⁾	HD ²⁾	K	L	LC	LD	O
355 SM_	28	25	90	106	81	95	16	14	355	52	725	944	958	35	1479	1659	467	130
355 ML_	28	25	90	106	81	95	16	14	355	52	725	944	958	35	1584	1764	467	130
355 LK_	28	25	90	106	81	95	16	14	355	52	725	944	958	35	1834	2014	467	130
400 L_	28	25	100	116	81	95	16	14	400	45	814	-	1045	35	1891	2071	498	150

Tolerances:

A, B	± 0,8	F	ISO h9
C, CA	± 0,8	H	+0 -0,5
D	ISO k6 < Ø 50mm	N	ISO j6
	ISO m6 > Ø 50mm		

¹⁾ Terminal box 370

²⁾ Terminal box 750

Above table gives the main dimensions in mm.

For detailed drawings please see our web site 'www.abb.com/motors&drives' or contact us.

Permanent magnet motors

Sizes 280 - 315

Cooling designation: IC 416, variant code 183;

Separate motor cooling, fan axial, N-end

Dimension drawings

Foot-mounted: IM B3 (IM 1001)

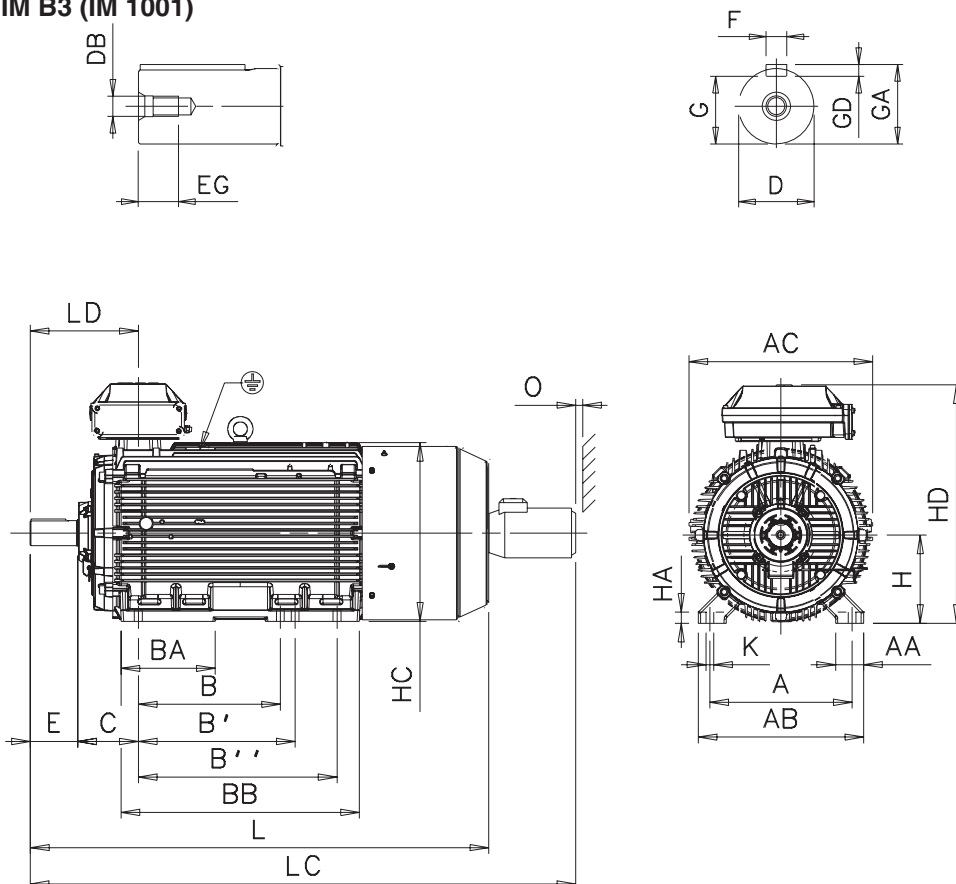

Motor size	A	AA	AB	AC	B	B'	B''	BA	BB	C	D	DB	E	EG	F
280 SM_	457	84	530	577	368	419	-	147	506	190	75	M20	140	40	20
315 SM_	508	100	590	654	406	457	-	180	558	216	80	M20	170	40	22
315 ML_	508	100	590	654	457	508	-	212	669	216	90	M24	170	48	25
315 LK_	508	100	590	654	508	560	710	336	851	216	90	M24	170	48	25

Motor size	G	GA	GD	H	HA	HC	HD ¹⁾	HD ²⁾	K	L	LC	LD	O
280 SM_	67.5	79.5	12	280	31	564	762	-	24	1194	1472	336	25
315 SM_	71	85	14	315	40	639	852	-	28	1304	1582	386	25
315 ML_	81	95	14	315	40	639	852	-	28	1414	1692	386	25
315 LK_	81	95	14	315	40	639	852	880	28	1638	1950	386	25

Tolerances:

A, B	± 0,8	F	ISO h9
C, CA	± 0,8	H	+0 -0,5
D	ISO k6 < Ø 50mm	N	ISO j6
	ISO m6 > Ø 50mm		

¹⁾ Terminal box 370

²⁾ Terminal box 750

Above table gives the main dimensions in mm.

For detailed drawings please see our web site 'www.abb.com/motors&drives' or contact us.

Permanent magnet motors

Sizes 355 - 400

Cooling designation: IC 416, variant code 183;

Separate motor cooling, fan axial, N-end

Dimension drawings

Foot-mounted: IM B3 (IM 1001)

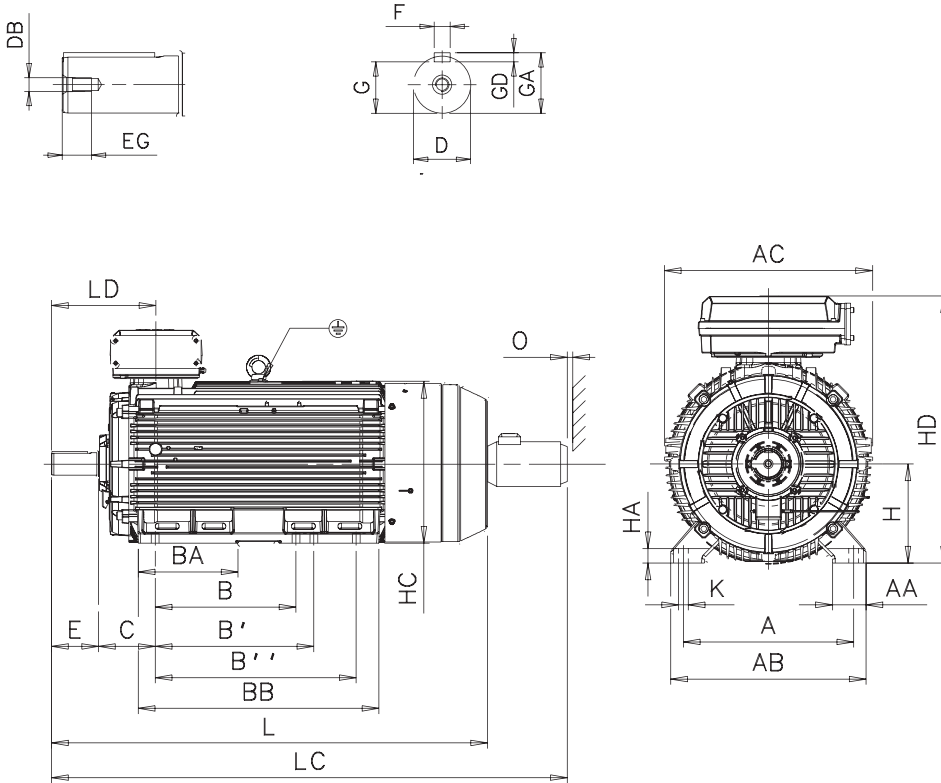

Motor size	A	AA	AB	AC	B	B'	B''	BA	BB	C	D	DB	E	EG	F
355 SM_	610	120	700	746	500	560	-	221	722	254	100	M24	210	50	28
355 ML_	610	120	700	746	560	630	-	267	827	254	100	M24	210	50	28
355 LK_	610	120	700	746	630	710	900	447	1077	254	100	M24	210	50	28
400 L_	710	150	840	834	900	1000	-	410	1156	224	110	M24	210	50	28

Motor size	G	GA	GD	H	HA	HC	HD ¹⁾	HD ²⁾	K	L	LC	LD	O
355 SM_	90	106	16	355	52	725	944	958	35	1594	1905	467	25
355 ML_	90	106	16	355	52	725	944	958	35	1699	2056	467	25
355 LK_	90	106	16	355	52	725	944	958	35	1953	2310	467	25
400 L_	100	116	16	400	45	814	-	1045	35	1996	2353	498	25

Tolerances:

A, B	± 0,8	F	ISO h9
C, CA	± 0,8	H	+0 -0,5
D	ISO k6 < Ø 50mm ISO m6 > Ø 50mm	N	ISO j6

¹⁾ Terminal box 370

²⁾ Terminal box 750

Above table gives the main dimensions in mm.

For detailed drawings please see our web site
www.abb.com/motors&drives or contact us.

Permanent magnet motors

Sizes 280 - 315

Cooling designation: IC 416, variant code 422;

Separate motor cooling, fan top or side, N-end.

Dimension drawings

Foot-mounted: IM B3 (IM 1001)

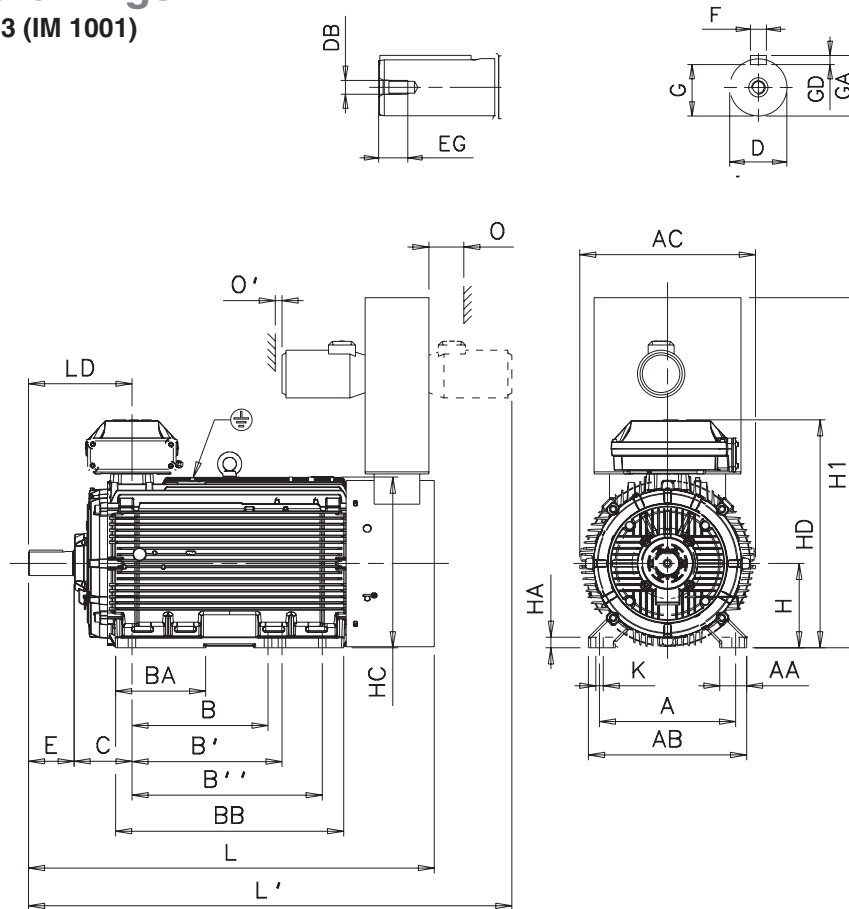

Motor size	A	AA	AB	AC	B	B'	B''	BA	BB	C	D	DB	E	EG	F
280 SM_	457	84	530	577	368	419	-	147	506	190	75	M20	140	40	20
315 SM_	508	100	590	654	406	457	-	180	558	216	80	M20	170	40	22
315 ML_	508	100	590	654	457	508	-	212	669	216	90	M24	170	48	25
315 LK_	508	100	590	654	508	560	710	336	851	216	90	M24	170	48	25

Motor-size	G	GA	GD	H	HA	HC	HD ¹⁾	HD ²⁾	H1	K	L	L'	LD	O	O'
280 SM_	67.5	79.5	12	280	31	564	762	-	1245	24	1043	1333	336	130	25
315 SM_	71	85	14	315	40	639	852	-	1316	28	1246	1535	386	130	25
315 ML_	81	95	14	315	40	639	852	-	1316	28	1356	1645	386	130	25
315 LK_	81	95	14	315	40	639	852	880	1316	28	1516	1805	386	130	25

Tolerances:

A, B	± 0,8	F	ISO h9
C, CA	± 0,8	H	+0 -0,5
D	ISO k6	N	ISO j6
	ISO m6 > Ø 50mm		

¹⁾ Terminal box 370

²⁾ Terminal box 750

Above table gives the main dimensions in mm.

For detailed drawings please see our web site 'www.abb.com/motors&drives' or contact us.

Permanent magnet motors

Sizes 355 - 400

Cooling designation: IC 416, variant code 422;

Separate motor cooling, fan top or side, N-end.

Dimension drawings

Foot-mounted: IM B3 (IM 1001)

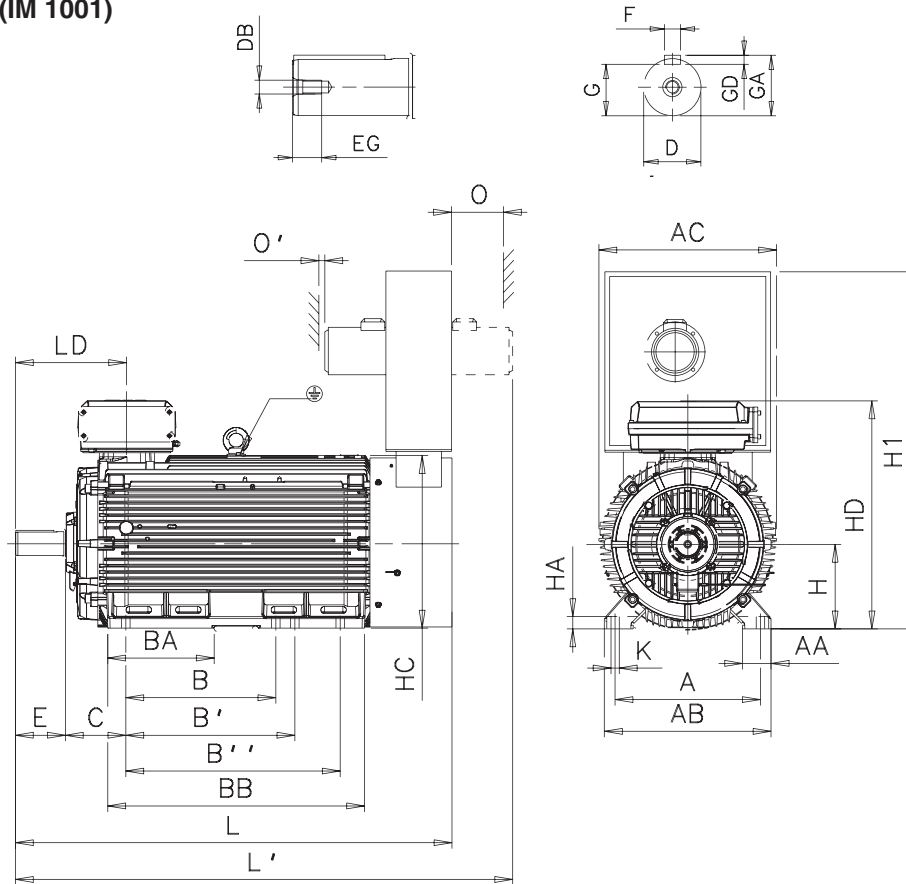

Motor size	A	AA	AB	AC	B	B'	B''	BA	BB	C	D	DB	E	EG	F
355 SM_	610	120	700	746	500	560	-	221	722	254	100	M24	210	50	28
355 ML_	610	120	700	746	560	630	-	267	827	254	100	M24	210	50	28
355 LK_	610	120	700	746	630	710	900	447	1077	254	100	M24	210	50	28
400 L_	710	150	840	834	900	1000	-	410	1156	224	110	M24	210	50	28

Motor-size	G	GA	GD	H	HA	HC	HD ¹⁾	HD ²⁾	H1	K	L	L'	LD	O	O'
355 SM_	90	106	16	355	52	725	944	958	1500	35	1514	1771	467	130	25
355 ML_	90	106	16	355	52	725	944	958	1500	35	1584	1841	467	130	25
355 LK_	90	106	16	355	52	725	944	958	1500	35	1834	2091	467	130	25
400 L_	100	116	16	400	45	814	-	1045	1593	35	1891	2148	498	130	25

Tolerances:

A, B	± 0,8	F	ISO h9
C, CA	± 0,8	H	+0 -0,5
D	ISO k6	N	ISO j6
	ISO m6 > Ø 50mm		

¹⁾ Terminal box 370

²⁾ Terminal box 750

Above table gives the main dimensions in mm.

For detailed drawings please see our web site www.abb.com/motors&drives or contact us.

Cooling designation: Water cooled

Dimension drawings

Foot-mounted

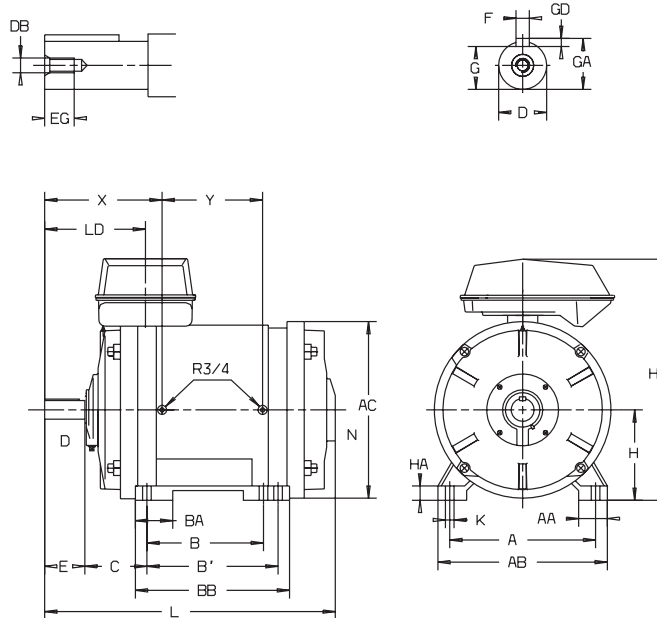

Motor size	A	AA	AB	AC	B	B'	BA	BB	C	D ¹⁾	DB	E	EG
280 SM_	457	85	530	544	368	419	135	470	190	75	M20	140	40
315 SM_	508	100	590	615	406	457	130	537	216	80	M20	170	40
315 ML_	508	100	590	615	457	508	130	588	216	90	M24	170	48
315 LK_	508	100	590	615	508	710	130	805	216	90	M24	170	48

Motor size	F	G	GA	GD	H	HA ¹⁾	HD	K	L	LD	X	Y
280 SM_	20	67.5	79.5	12	280	40	745	24	932	332	390	300
315 SM_	22	71	85	14	315	50	840	30	1042	381	440	350
315 ML_	25	81	95	14	315	50	840	30	1093	381	440	400
315 LK_	25	81	95	14	315	50	840	30	1310	381	440	420

¹⁾ Tolerances:
 D ISO m6
 H ISO 0, -1.0

Above table gives the main dimensions in mm.

For detailed drawings please see our web site 'www.abb.com/motors&drives' or contact us.

Permanent magnet motors

Sizes 355-400

Cooling designation: Water cooled

Dimension drawings

Foot-mounted

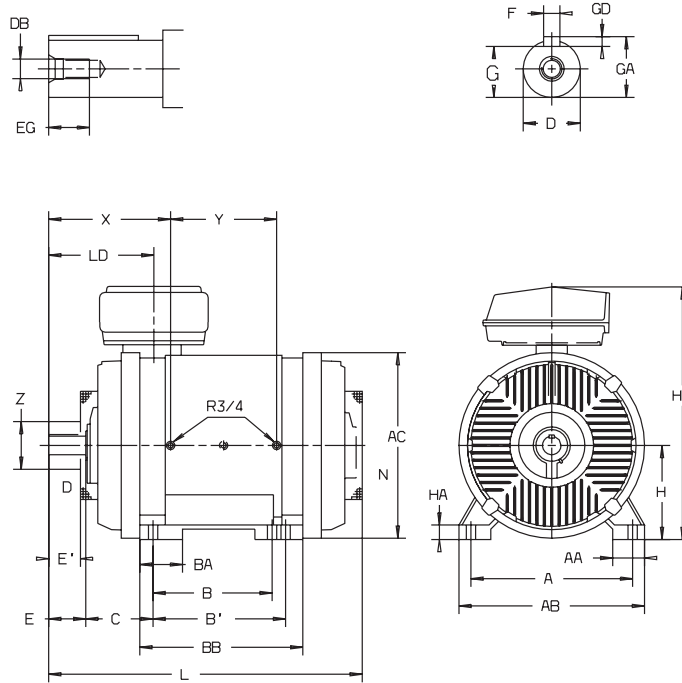

Motor size	A	AA	AB	AC	B	B'	BA	BB	C	D	DB	E	E'	EG
355 SM_	610	120	700	700	500	560	161	667	254	100	M24	210	190	48
355 ML_	610	120	700	700	560	630	161	772	254	100	M24	210	190	48
355 LK_	610	120	700	700	630	900	161	1028	254	100	M24	210	190	45
400 L_	3)													

Motor size	F	G	GA	GD	H	HA ¹⁾	HD	K	L	LD	X	Y	Z ²⁾
355 SM_	28	90	106	16	355	55	955	35	1282	467	530	450	180
355 ML_	28	90	106	16	355	55	955	35	1387	467	530	550	180
355 LK_	28	90	106	16	355	55	955	35	1643	467	530	800	180
400 L_	3)												

1) Tolerances:

D ISO m6

H ISO 0, -1.0

2) Note: Motor sizes 355 to 400 with a bearing fan.

3) On request

Above table gives the main dimensions in mm.

For detailed drawings please see our web site 'www.abb.com/motors&drives' or contact us.

Permanent magnet motors, frame sizes 280 to 400

Dimension drawings

Terminal boxes, standard design with 6 terminals

See section 'Terminal box for frame sizes 280 to 400' for terminal box type.

Top-mounted

Terminal boxes 210, 370

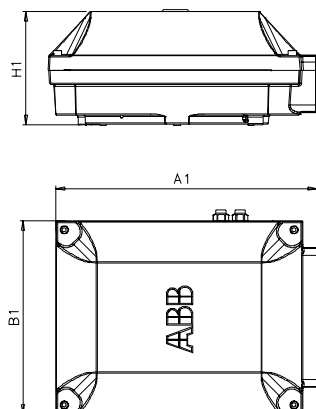

Top-mounted

Terminal box 750 + adapter

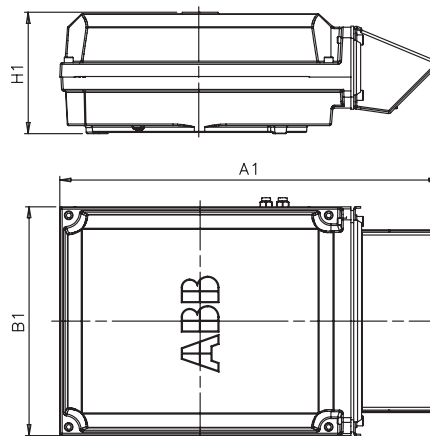

Motor sizes 280 - 400	A1	B1	H1
Terminal box type			
210	416	306	177
370	451	347	200
750 top-mounted	686	413	219

For motor dimensions please see dimension drawings on earlier pages or on our web site 'www.abb.com/motors&drives'.

Permanent magnet motors

Sizes 500 and 560

Cooling designation: IC 411

Dimension drawings

Foot-mounted: IM B3 (IM 1001)

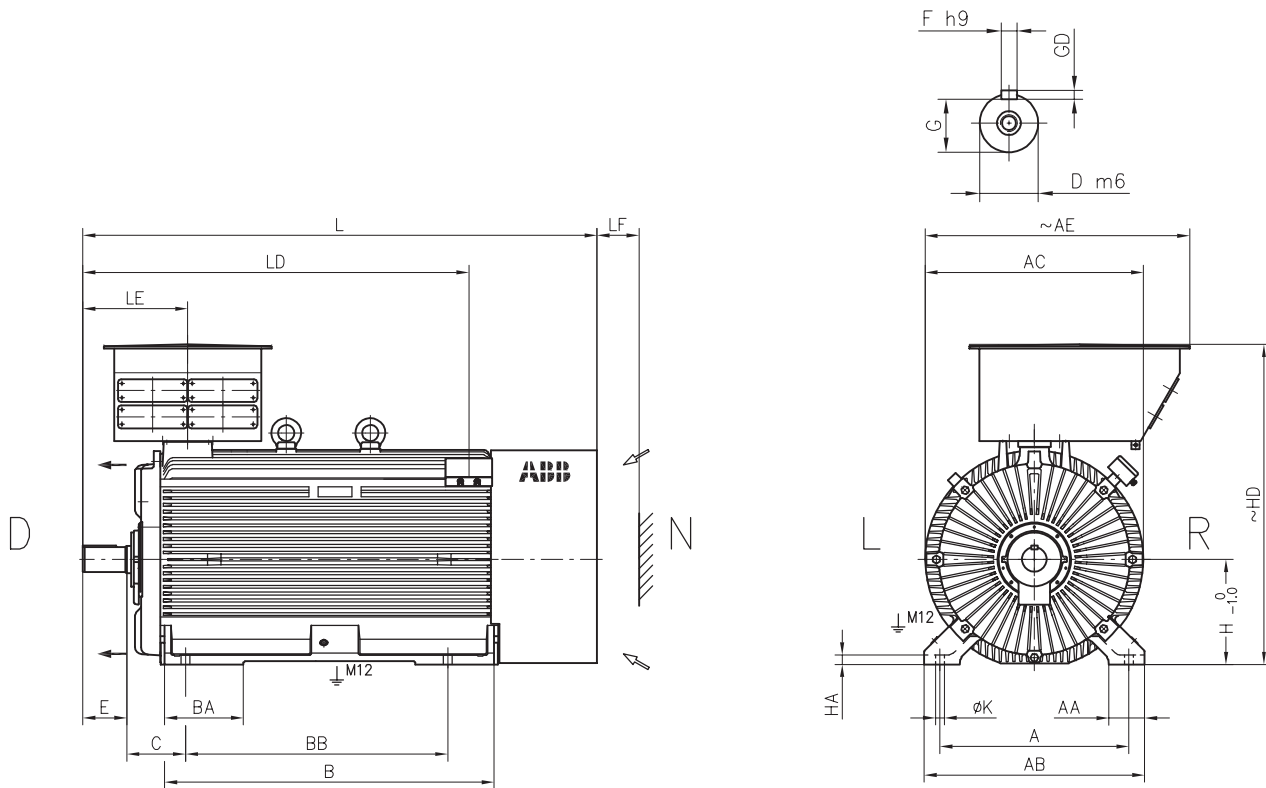

Motor AMZ	Poles	A	AA	AB	AC	AE	B	BA	BB	C	D	E	F	G	GD	H
0500L	10	900	170	1050	1035	1265	1570	375	1250	280	140	250	36	128	20	500
0560L	10	1000	230	1170	1190	1340	1940	620	1600	400	180	300	45	165	25	560

Motor AMZ	HA	HD	K	L	LD	LE	LF
0500L	45	1530	42	2535	1880	540	200
0560L	50	1675	48	3065	2350	630	250

Above table gives the main dimensions in mm.

For detailed drawings please see our web site
'www.abb.com/motors&drives' or contact us.

Permanent magnet motors

Sizes 500 and 560

Cooling designation: IC 411

Dimension drawings

Flange-mounted: IM V1 (IM 3011)

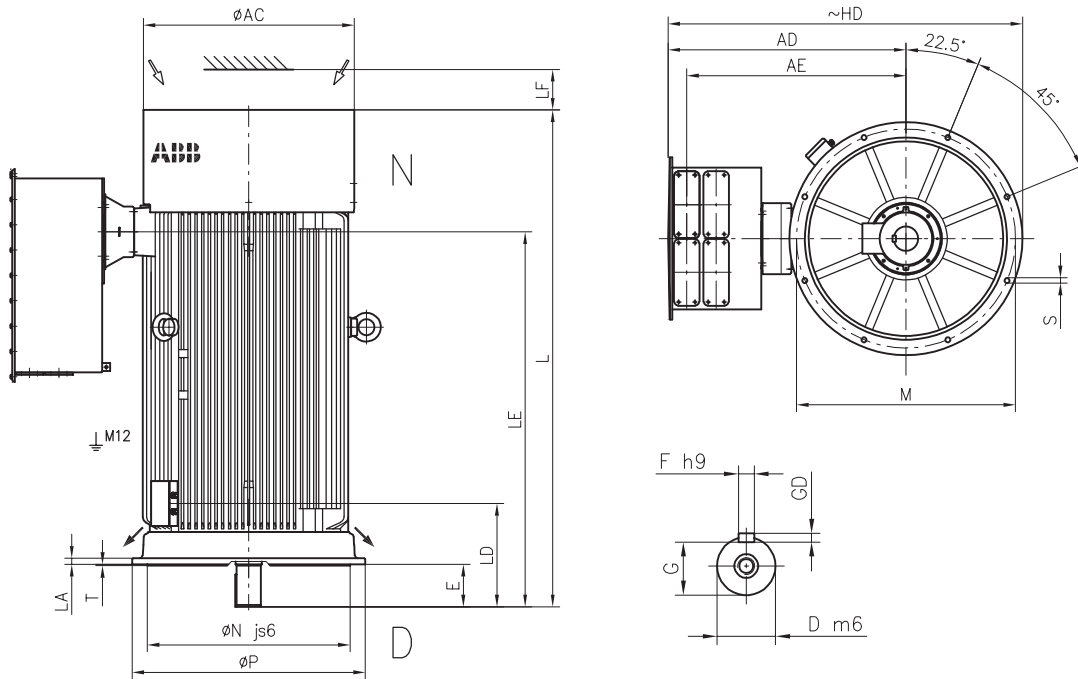

Motor AMZ	Poles	AC	AD	AE	D	E	F	G	GD	HD	L	LA	LD	LE	LF
0500L	10	1040	1175	1085	140	250	36	128	20	1750	2535	30	550	1890	200
0560L	10	1190	1260	1170	180	300	45	165	25	1965	3065	60	650	2370	250

Motor AMZ	M	N	P	S	T
0500L	1080	1000	1150	28	6
0560L	1320	1250	1400	28	6

Above table gives the main dimensions in mm.

For detailed drawings please see our web site 'www.abb.com/motors&drives' or contact us.

Permanent magnet motors

Sizes 500 and 560

Cooling designation: IC 416

Separate motor cooling, fan axial, N-end

Dimension drawings

Foot-mounted: IM B3 (IM 1001)

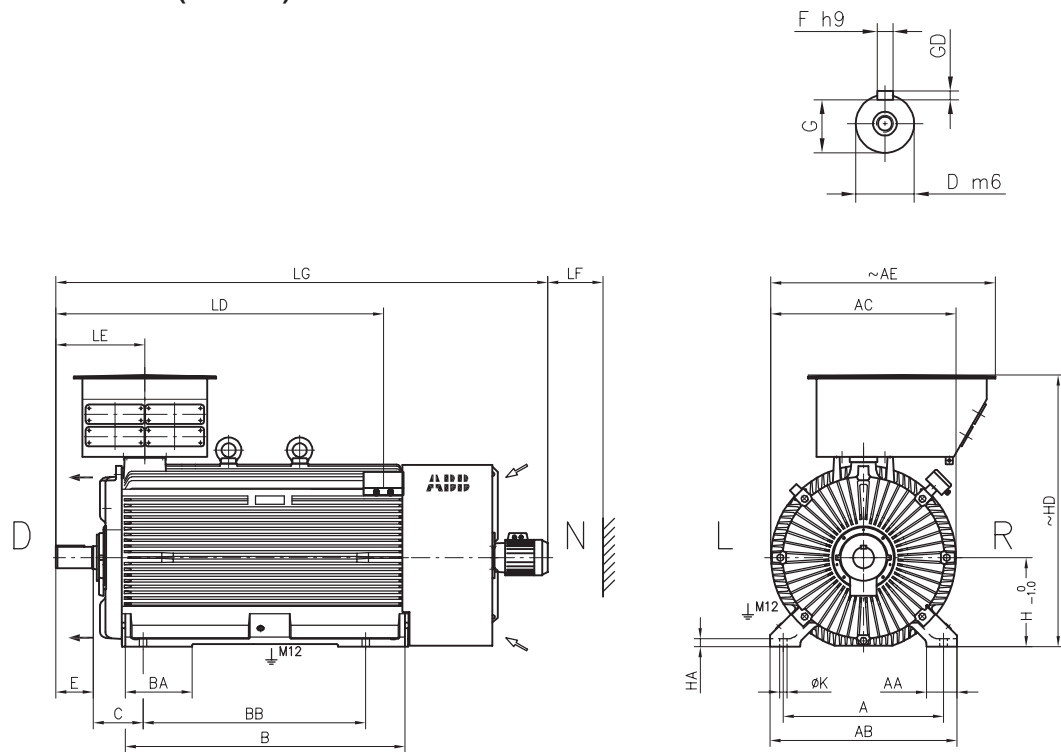

Motor AMZ	Poles	A	AA	AB	AC	AE	B	BA	BB	C	D	E	F	G	GD	H
0500L	10	900	170	1050	1035	1265	1570	375	1250	280	140	250	36	128	20	500
0560L	10	1000	230	1170	1190	1340	1940	620	1600	400	180	300	45	165	25	560

Motor AMZ	HA	HD	K	LD	LE	LG	LF
0500L	45	1530	42	1880	540	2850	310
0560L	50	1675	48	2350	630	3410	300

Above table gives the main dimensions in mm.

For detailed drawings please see our web site 'www.abb.com/motors&drives' or contact us.

Permanent magnet motors

Sizes 500 to 560

Cooling designation: IC 416

Separate motor cooling, fan axial, N-end

Dimension drawings

Flange-mounted: IM V1 (IM 3011)

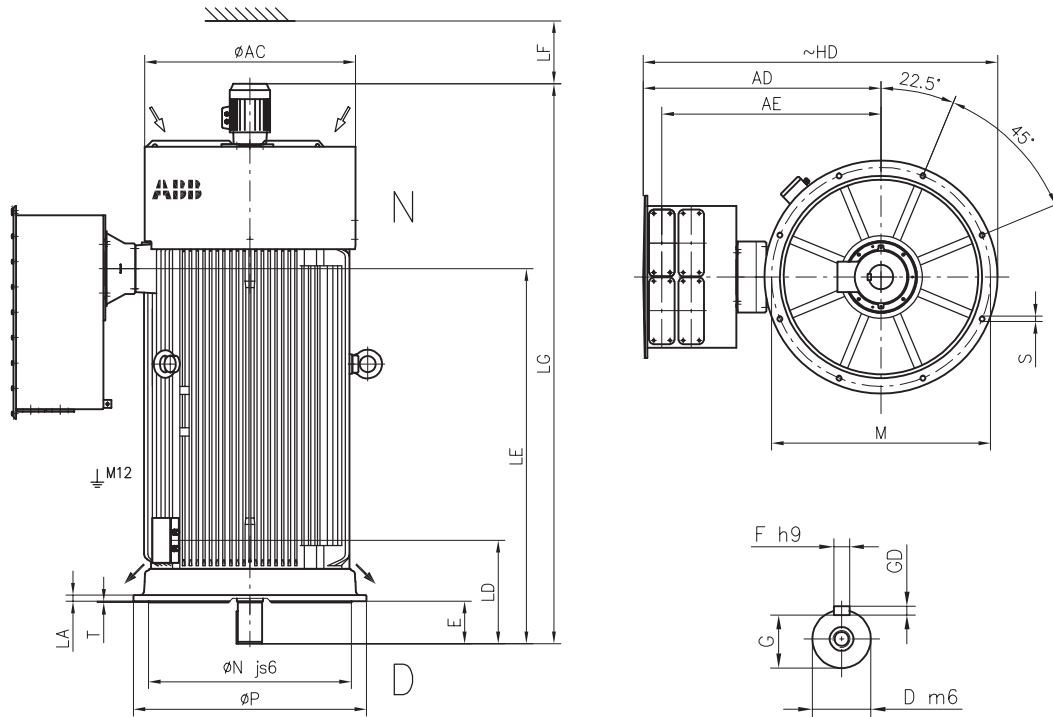

Motor AMZ	Poles	AC	AD	AE	D	E	F	G	GD	HD	LA	LD	LE
0500L	10	1040	1175	1085	140	250	36	128	20	1750	30	550	1890
0560L	10	1190	1260	1170	180	300	45	165	25	1965	60	650	2370

Motor AMZ	LF	LG	M	N	P	S	T
0500L	310	2850	1080	1000	1150	28	6
0560L	300	3410	1320	1250	1400	28	6

Above table gives the main dimensions in mm.

For detailed drawings please see our web site
'www.abb.com/motors&drives' or contact us.

Permanent magnet motors

Sizes 500 and 560

Cooling designation: IC 416

Separate motor cooling, fan top , N-end.

Dimension drawings

Foot-mounted: IM B3 (IM 1001)

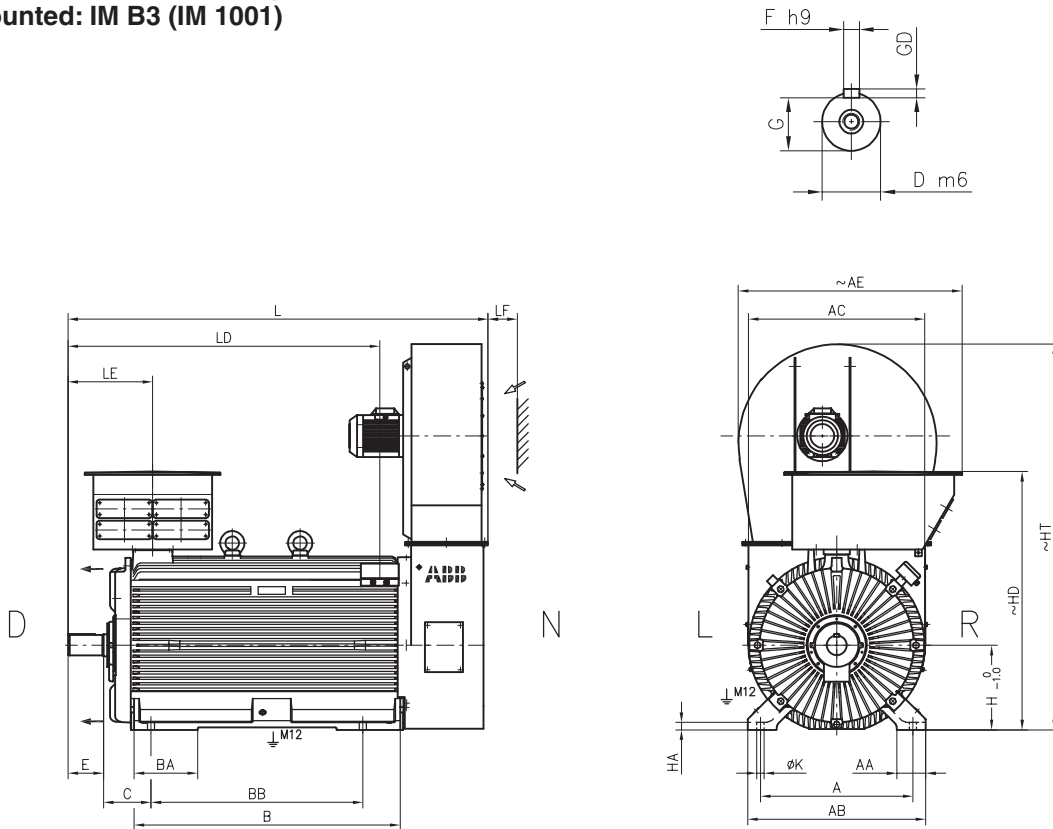

Motor AMZ	Poles	A	AA	AB	AC	AE	B	BA	BB	C	D	E	F	G
0500L	10	900	170	1050	1050	1325	1570	375	1250	280	140	250	36	128
0560L	10	1000	230	1170	1200	1345	1940	620	1600	400	180	300	45	165

Motor AMZ	GD	H	HA	HD	HT	K	L	LD	LE	LF
0500L	20	500	45	1530	2280	42	2525	1880	540	200
0560L	25	560	50	1675	2400	48	3055	2350	630	250

Above table gives the main dimensions in mm.

For detailed drawings please see our web site 'www.abb.com/motors&drives' or contact us.

Permanent magnet motors

Sizes 500 to 560

Cooling designation: IC71W

Dimension drawings

Foot-mounted: IM B3 (IM 1001)

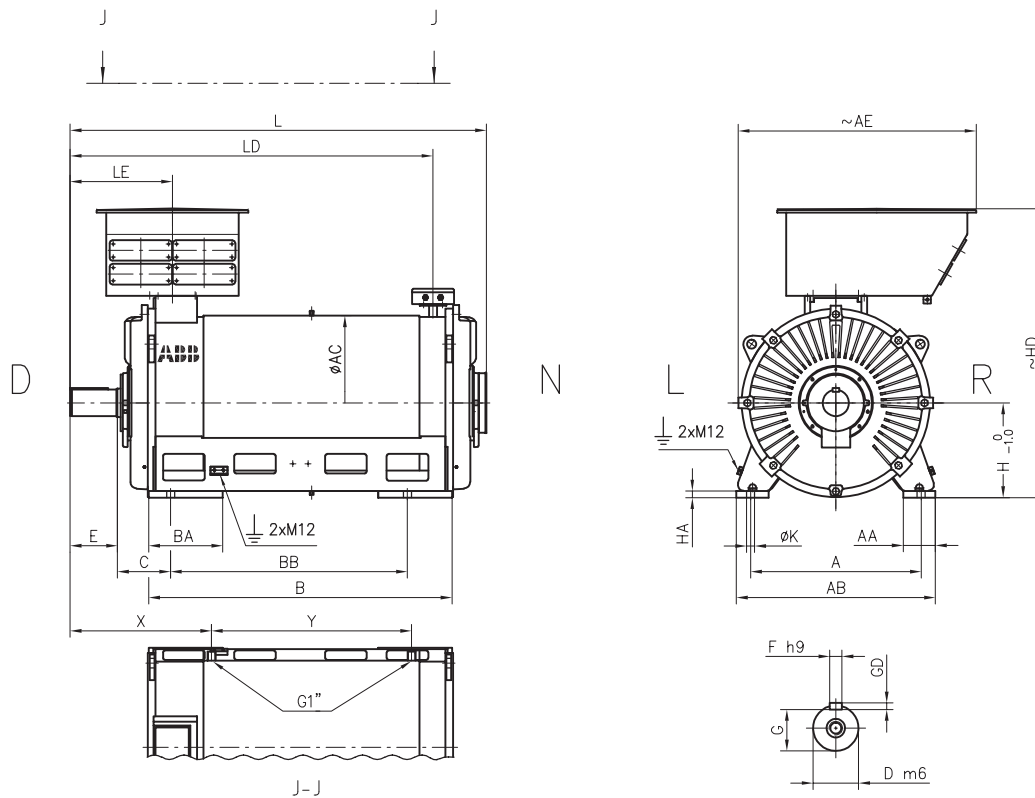

Motor AMZ	Poles	A	AA	AB	AC	AE	B	BA	BB	C	D	E	F	G
0500L	10	900	170	1050	920	1265	1600	390	1250	280	140	250	36	128
0560L	10	1000	230	1170	1040	1300	1940	620	1600	400	180	300	45	165

Motor AMZ	GD	H	HD	L	LD	LE	X	Y
0500L	20	500	1530	2195	1915	540	746	1056
0560L	25	560	1675	2830	2395	655	836	1446

Above table gives the main dimensions in mm.

For detailed drawings please see our web site 'www.abb.com/motors&drives' or contact us.

Permanent magnet motors

Sizes 500 to 560

Cooling designation: IC71W

Dimension drawings

Flange-mounted: IM V1 (IM 3011)

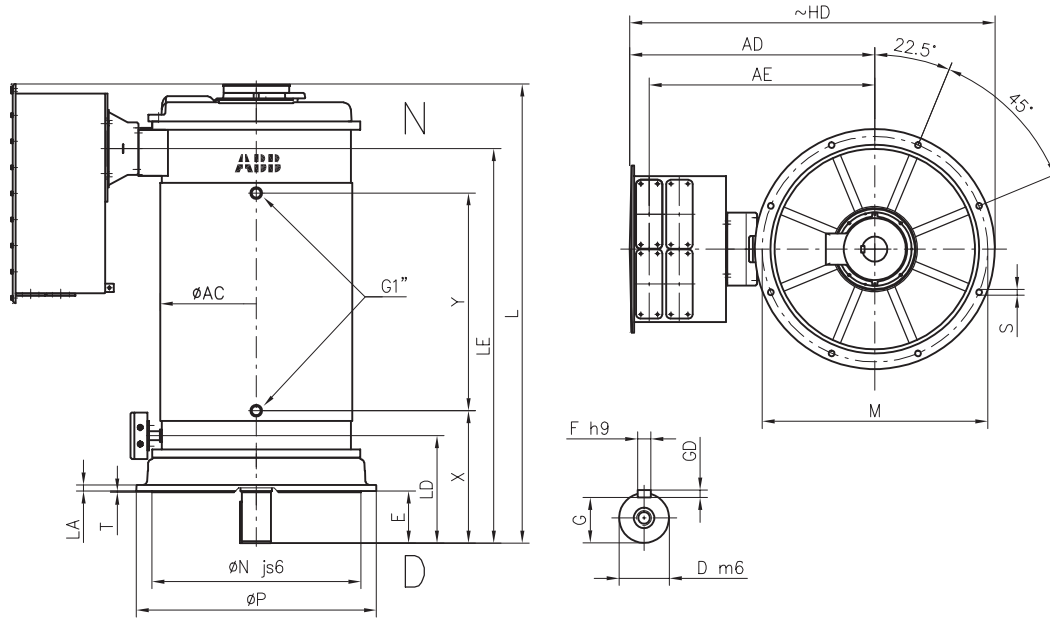

Motor AMZ	Poles	AC	AD	AE	D	E	F	G	GD	HD	L	LA	LD
0500L	10	1020	1175	1080	140	250	36	128	20	1750	2160	30	475
0560L	10	1150	1260	1170	180	300	45	165	25	1965	2800	60	605

Motor AMZ	LE	M	N	P	S	T	X	Y
0500L	1830	1080	1000	1150	28	6	746	1056
0560L	2345	1320	1250	1400	28	6	718	1446

Above table gives the main dimensions in mm.

For detailed drawings please see our web site 'www.abb.com/motors&drives' or contact us.

Permanent magnet motors inbrief, basic design

Motor size		280	315	355	400	500	560
Stator	Material	Cast iron EN-GJL-200/GG 20/GRS 200					
	Paint colour shade	Blue, Munsell 8B 4.5/3.25 / NCS 4822 B05G					
	Paint	Two-pack epoxy paint					
	Paint thickness	≥ 70 µm				≥ 180 µm	
Bearing end shields	Material	Cast iron EN-GJL200/GG 20/GRS 200, EN-GJL 250/GG 25/GRS 250, EN-GJS-400/GG40/GRP 400				Cast iron EN-GJL200	
	Paint colour shade	Blue, Munsell 8B 4.5/3.25 / NCS 4822 B05G					
	Paint thickness	Two-pack epoxy paint, thickness ≥ 70 µm				≥ 180 µm	
Bearings	D-end	6316/C3	6319/C3	6322/C3	6324/C3	6330/C3	6338/C3
	N-end	6316/C3 VL024	6316M/C3 VL024	6316M/C3 VL024	6319M/C3 VL024	IM 1001: 6330/C3 IM 3011: 7330 BM	IM1001: 6338/C3 IM 3011: 7338 BM
Axially-locked bearings	Inner bearing cover	As standard, locked at D-end				IM 1001: Locked at D-end IM 3011: Locked at N-end	
Bearing seals		V-ring or labyrinth seal as standard, see tables in chapter 'Bearing seals'				Labyrinth seal in both ends	
Lubrication		Regreasable bearings, regreasing nipples, M10x1					
SPM-nipples		As standard					
Rating plate	Material	Stainless steel, EN 10088					
Terminal box	Frame material	Cast iron EN-GJL250/GG 25/GRS 250				Structural steel, S235JRG2- EN 10025, thickness 3 mm	
	Cover material	Cast iron EN-GJL250/GG 25/GRS 250				Structural steel, S235JRG2- EN 10025, thickness 3 mm	
	Cover screws material	Steel 8.8, zinc electroplated and yellow cromated				Steel 8.8, Delta-Tone 9000	
Connections		Please see the chapters 'Terminal box'					
Fan	Material	Glass fibre reinforced plastic or aluminum				Structural steel, S235JRG2- EN 10025	
Fan cover	Material	Steel				Structural steel, S235JRG2- EN 10025, thickness 3 mm	
	Paint colour shade	Blue, Munsell 8B 4.5/3.25 / NCS 4822 B05G					
	Paint	Two-pack polyester powder paint					
	Paint thickness	≥ 80 µm				≥ 180 µm	
Stator winding	Material	Copper				Form wound copper	
	Insulation	Insulation class F					
	Winding protection	3 Pt-100, 2-wire connection				6 Pt-100, 3-wire connection	
Rotor winding	Material	Permanent magnet rotor					
Balancing method		Half key balancing as standard					
Key way		Open key way					
Heating elements	On request	50 W	2x50 W	2x65 W	2x65 W	400 W	500 W
Drain holes		Standard, open on delivery					
Enclosure		IP 55, higher protection on request					
Cooling method		IC 411, IC 416				IC 411, IC 416, IC 71W	

ABB Motors' total product offer

ABB offers several comprehensive ranges of AC motors and generators. We manufacture synchronous motors for even the most demanding applications, and a full range of low and high voltage induction motors. Our in-depth knowledge of virtually every type of industrial processing ensures we always specify the best solution for your needs.

Low voltage motors and generators

General purpose motors for standard applications

- Aluminum motors
- Steel motors
- Cast iron motors
- Open drip proof motors
- Brake motors
- Single phase motors
- Integral motors

Process performance motors for more demanding applications

- Aluminum motors
- Cast iron motors

Other applications

- Motors for hazardous areas
- Marine motors
- Permanent magnet motors
- High speed motors
- Wind turbine generators
- NEMA motors
- Water cooled motors
- Motors for roller table drives
- Slip ring motors
- Wood dryer motors
- Fan application motors

High voltage and synchronous motors and generators

- High voltage cast iron motors
- Induction modular motors
- Slip ring motors
- Motors for hazardous areas
- Servomotors
- Synchronous motors and generators
- DC motors and generators

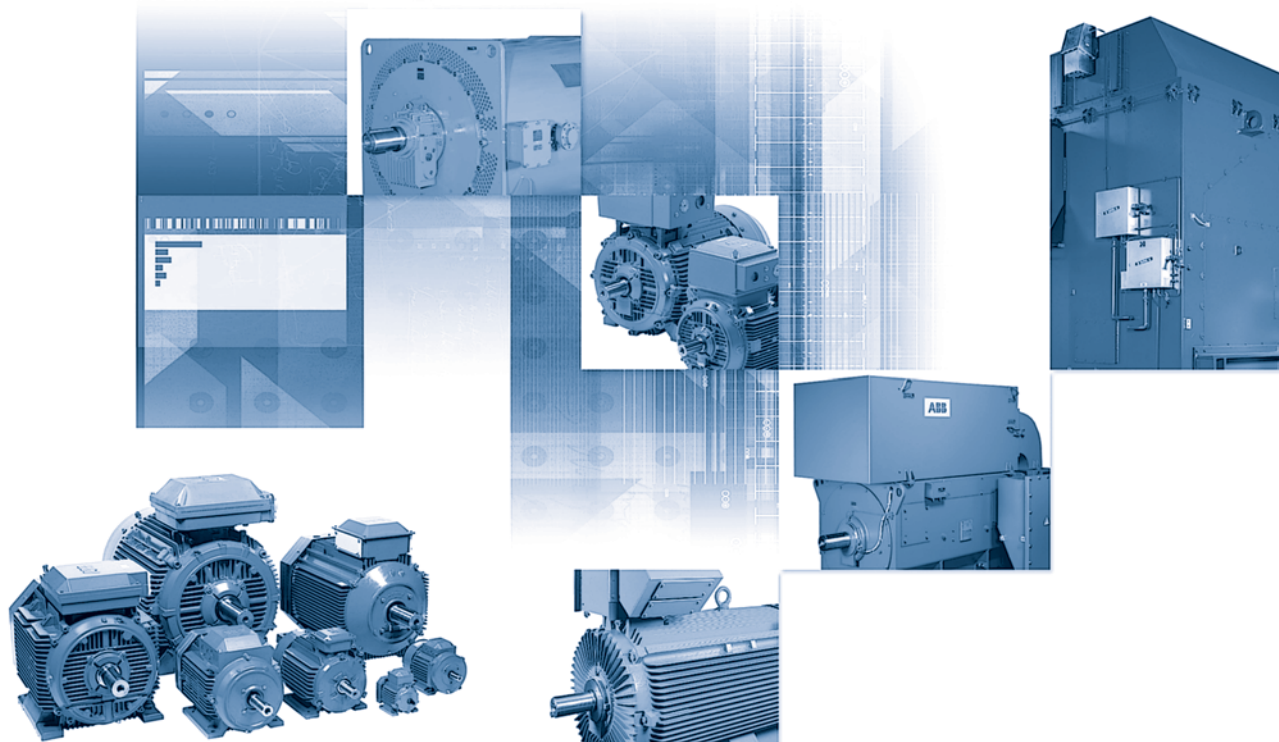

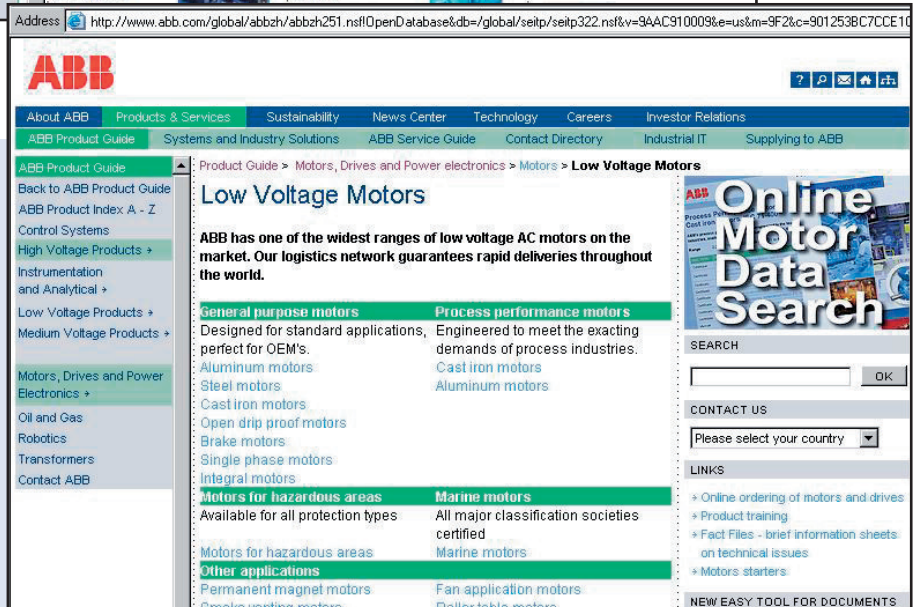
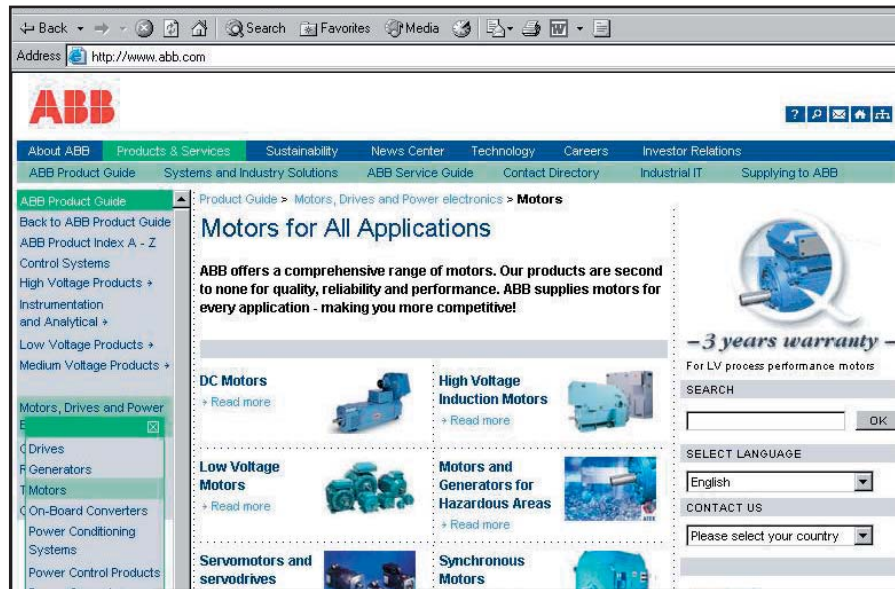

Motors & Drives

=> Motors

=> Low Voltage Motors

General purpose motors

Process performance motors

Motors for hazardous areas

Marine motors

Other applications

=> Permanent magnet motors

Smoke venting motors

Water cooled motors

Fan application motors

Roller table motors

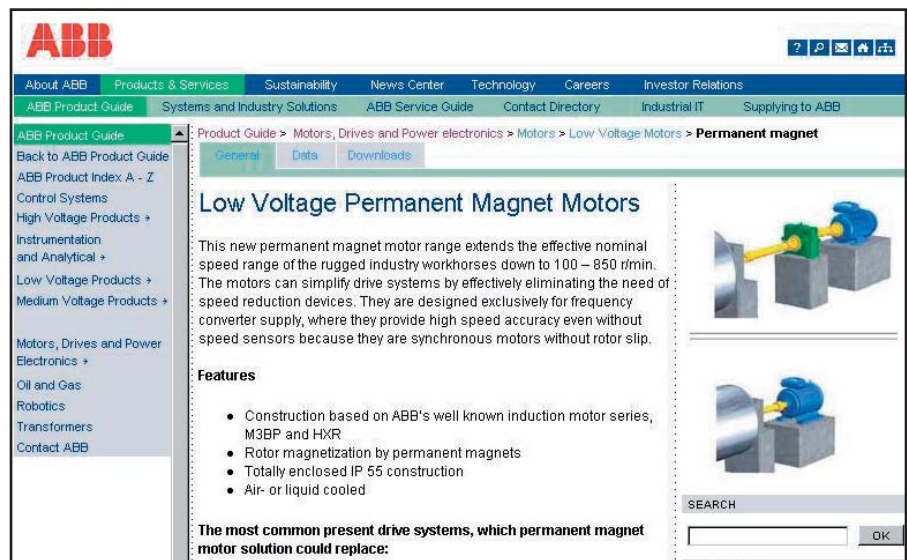

Drive^{IT} Low Voltage Motors

Manufacturing sites (*) and some of the larger sales companies.

Australia

ABB Industry Pty Ltd
2 Douglas Street
Port Melbourne,
Victoria, 3207
Tel: +61 (0) 3 9644 4100
Fax: +61 (0) 3 9646 9362

Austria

ABB AG
Wienerbergstrasse 11 B
AT-1810 Wien
Tel: +43 (0) 1 601 090
Fax: +43 (0) 1 601 09 8305

Belgium

Asea Brown Boveri S.A.-N.V.
Hoge Wei 27
BE-1930 Zaventem
Tel: +32 (0) 2 718 6311
Fax: +32 (0) 2 718 6657

Canada

ABB Inc., BA Electrical Machines
10300 Henri-Bourassa Blvd, West,
Saint-Laurent, Quebec
Canada H4S 1N6
Tel: +1 514 832-6583
Fax: +1 514 332-0609

China*

ABB Shanghai Motors
Company Limited
8 Guang Xing Rd., Rong Bei
Town, Songjiang County,
Shanghai 201613
Tel: +86 21 5778 0988
Fax: +86 21 5778 1364

Chile

Asea Brown Boveri S.A.
P.O.Box 581-3
Santiago
Tel: +56 (0) 2 5447 100
Fax: +56 (0) 2 5447 405

Denmark

ABB A/S
Automation Technology Electrical
Machines
Petersmindevej 1
DK-5000 Odense C
Tel: +45 65 477 070
Fax: +45 65 477 713

Finland*

ABB Oy
LV Motors
P.O.Box 633
FI-65101 Vaasa
Tel: +358 (0) 10 22 11
Fax: +358 (0) 10 22 47372

France

ABB Automation
Rue du Général de Gaulle
Champagne-sur-Seine
FR-77811 Moret-sur-Loing
Cedex
Tel: +33 (0) 1 60 746 500
Fax: +33 (0) 1 60 746 565

Germany

ABB Automation Products GmbH
Edisonstrasse 15
DE-68623 Lampertheim
Tel: +49 (0) 6206 503 503
Fax: +49 (0) 6206 503 600

Hong Kong

ABB (Hong Kong) Ltd.
Tai Po Industrial Estate,
3 Dai Hei Street,
Tai Po, New Territories,
Hong Kong
Tel: +852 2929 3838
Fax: +852 2929 3505

India*

ABB Ltd.
32, Industrial Area, N.I.T
Faridabad 121 001
Tel: +91 (0) 129 502 3001
Fax: +91 (0) 129 502 3006

Indonesia

PT. ABB Sakti Industri
JL. Gajah Tunggal Km.1
Jatiuwung, Tangerang 15136
Banten, Indonesia
Tel: + 62 21 590 9955
Fax: + 62 21 590 0115 - 6

Ireland

Asea Brown Boveri Ltd
Components Division
Belgard Road
Tallaght, Dublin 24
Tel: +353 (0) 1 405 7300
Fax: +353 (0) 1 405 7327

Italy*

ABB SACE SpA
LV Motors
Via Della Meccanica, 22
IT-20040 Caponago - MI
Tel: +39 02 959 6671
Fax: +39 02 959 667216

Japan

ABB K.K.
26-1 Cerulean Tower
Sakuragaoka-cho, Shibuya-ku
Tokyo 150-8512
Tel: +81 (0) 3 578 46251
Fax: +81 (0) 3 578 46260

Korea

ABB Korea Ltd.
7-9fl, Oksan Bldg., 157-33
Sungshung-dong, Kangnam-ku
Seoul
Tel: +82 2 528 2329
Fax: +82 2 528 2338

Malaysia

ABB Malaysia Sdn. Bhd.
Lot 608, Jalan SS 13/1K
47500 Subang Jaya, Selangor
Tel: +60 3 5628 4888
Fax: +60 3 5631 2926

Mexico

ABB México, S.A. de C.V.
Apartado Postal 111
CP 54000 Tlalnepantla
Edo. de México, México
Tel: +52 5 328 1400
Fax: +52 5 390 3720

The Netherlands

ABB B.V.
Dept. LV motors (APP2R)
P.O.Box 301
NL-3000 AH Rotterdam
Tel: +31 (0) 10 4078 879
Fax: +31 (0) 10 4078 345

Norway

ABB AS
Automation Technology Products
Division
P.O.Box 6540 Rodeloekka
NO-0501 Oslo 5
Tel: +47 22 872 000
Fax: +47 22 872 541

Singapore

ABB Industry Pte Ltd
Singapore 139935
2 Ayer Rajah Crescent
Singapore 139935
Tel: +65 6776 5711
Fax: +65 6778 0222

Spain*

ABB Automation Products S.A.
Division Motores
P.O.Box 81
ES-08200 Sabadell
Tel: +34 93 728 8500
Fax: +34 93 728 8741

Sweden*

ABB Automation Technologies AB
LV Motors
SE-721 70 Västerås
Tel: +46 (0) 21 329 000
Fax: +46 (0) 21 124 103

Switzerland

ABB Schweiz AG
Normelec/CMC Components
Motors&Drives
Badenerstrasse 790
Postfach
CH-8048 Zürich
Tel: +41 (0) 58 586 0000
Fax: +41 (0) 58 586 0603

Taiwan

ABB Ltd.
6F, No. 126, Nanking East Road,
Section 4i
Taipei, 105 Taiwan, R.O.C.
Tel: +886 (0) 2 2577 6090
Fax: +886 (0) 2 2577 9467

Thailand

ABB Limited (Thailand)
161/1 SG Tower,
Soi Mahadlekluang 3,
Rajdamri, Bangkok 10330
Tel: +66 2 665 1000
Fax: +66 2 6042

The United Kingdom

ABB Automation Ltd
9 The Towers, Wilmslow Road
Didsbury
Manchester, M20 2AB
Tel: +44 (0) 161 445 5555
Fax: +44 (0) 161 448 1016

USA

ABB Inc.
Electrical Machines
P.O.Box 372
Milwaukee
WI 53201-0372
Tel: +1 262 785 3200
Fax: +1 262 785 8628

Venezuela

Asea Brown Boveri S.A.
P.O.Box 6649
Carmelitas,
Caracas 1010A
Tel: +58 (0) 2 238 2422
Fax: +58 (0) 2 239 6383



<http://www.abb.com/motors&drives>
<http://online.abb.com/motors&drives>